

ILLUSTRATED PARTS LIST

SPACER KIT

Model Number 11886E1
Effective Date 3-15-73
Form Number 20776L1

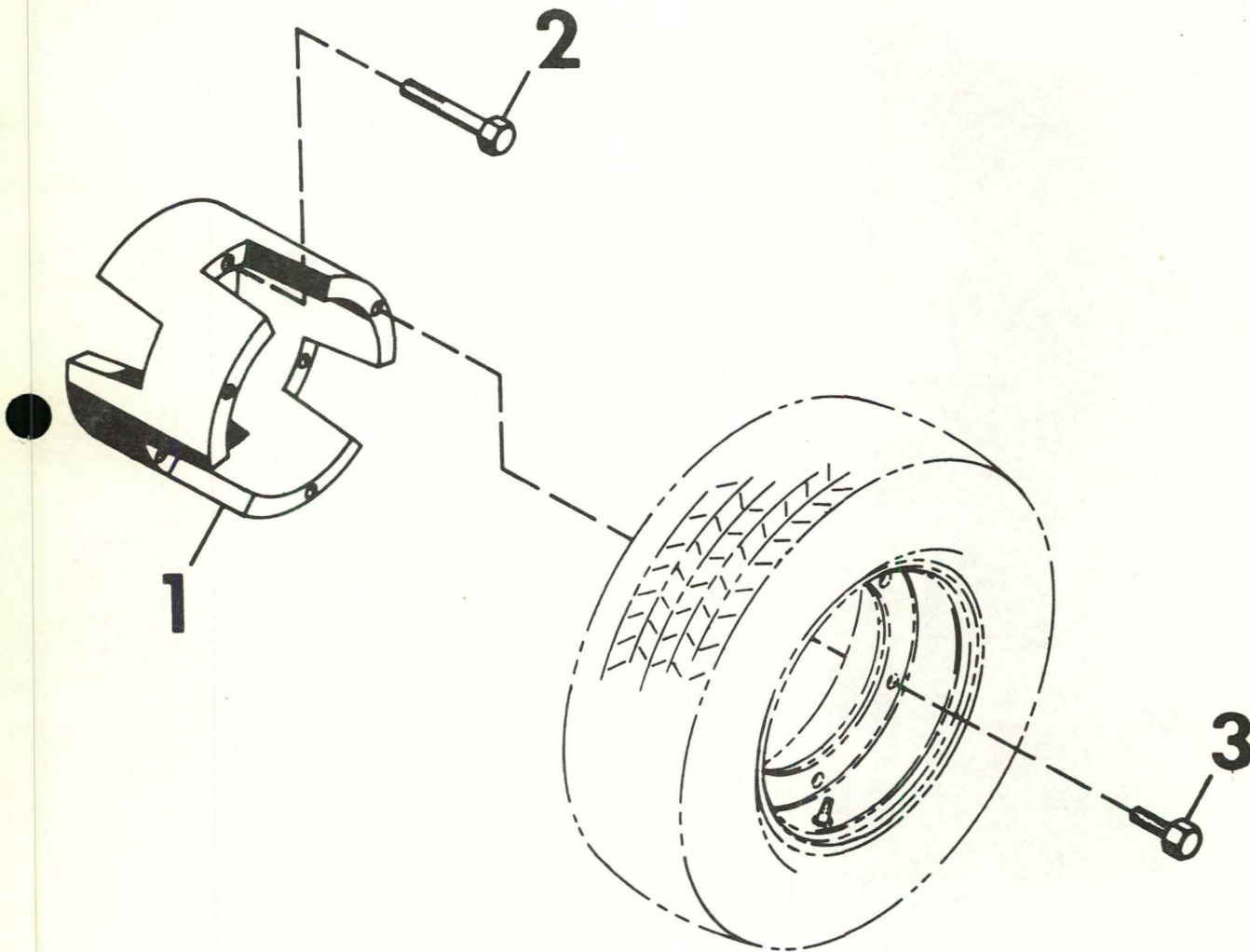

ITEM NO.

PART NO.

DESCRIPTION

1
2
3

12745P2
189305
9428638

Spacer, Dual Wheel
Bolt, Hex 3/8-16 x 3-1/2
Bolt, Hex 3/8-16 x 5/8