

# SUPER TOMAHAWK

5-8-2G/C

# TOMAHAWK

5-8-2G/M



TOMAHAWK



SUPER TOMAHAWK

## OWNER'S MANUAL

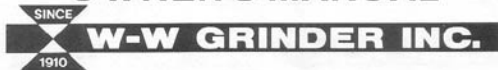

2957 N. Market • P.O. Box 4029 • Wichita, Kansas 67204

1-316-838-4229

TOLL FREE 1-800-835-2127



Mail: P.O. Box 4029, Wichita, Kansas, 67204 • Office and Factory: 2957 N. Market • Telephone (316) 838-4229

Dear Friend,

We believe that many of us appreciate, certainly all of us enjoy, the natural abundant beauty we have on earth. Most of this beauty, comfort, and nourishment comes from the trees and other plant life we are so blessed with. Mother Nature helps to perpetuate this life-giving process for us by making her own compost.

Leaves, trimmings, grass and other material drop to the ground. Animal wastes and moisture then mix with these organic materials forming a compound. This mixture decays and returns as natural growth energy to feed plants and protect the soil.

Here at W-W Grinder we are specialists in making machines that break, shred, or grind organic materials and other wastes. In breaking down materials we accelerate the natural decomposition process. Following nature's formula and adding moisture with some manure we can quickly convert this mixture into rich organic compost . . . compost that can be applied as an effective but safe fertilizer for your vegetables and flowers.

It's a pleasure to introduce you to the "Tomahawk" series of fine composting machines.

The original Tomahawk was produced in March 1982 as a compact Shredder/Grinder designed for the city or suburban homeowner. Attractively priced and with quality features, it became our biggest seller. Its compact mobility with big-machine performance have given it wide acceptance all over America.

Inspired, we have now developed the "Super Tomahawk," a Big Little Brother.

The low center of gravity position of the grinding cylinder on the Tomahawk seemed to us a very workable area to locate a chipper. Feeding long limbs into a chipper chute at waist high would be efficient and less fatiguing than pulling down. With this natural angle of feed, the body weight could be used to make it easy to exert downward pressure.

We designed a chipper assembly containing a full circle steel flywheel with a die steel blade.

This was mounted, outboard, to a new cylinder design and dynamically balanced. The result was a smooth powerful performance in grinding and chipping.

Now we have the original "Tomahawk" Shredder/Grinder and the "Super Tomahawk" which combines a chipper and a Shredder/Grinder . . . both with the quality and durability that W-W is famous for.

You'll be as proud to own one as we are to build them.

Happy Composting,

**W-W-GRINDER INC.**

MANUFACTURERS OF GRINDING, PULVERIZING AND SHREDDING MACHINERY

# TABLE OF CONTENTS

Points of Interest.....	4
Specifications.....	4
Safety Instructions.....	5
General Operating Information.....	6-8
Uncrating and Assembly.....	9
Parts Lists & Drawings—Super Tomahawk.....	10-15
Cylinder Assembly Drawing and Parts List.....	16
Parts Lists and Drawings—Tomahawk.....	17-20
Maintenance Tips.....	21-22
Briggs & Stratton Engine.....	23-25
Tecumseh Engine.....	26-28

## ONE-YEAR LIMITED WARRANTY

W-W Grinder Inc. warrants to the original purchaser of this product that the same is free of defects in materials or workmanship for a period of one (1) year from the date of purchase, and agrees to repair or replace at no cost to purchaser for labor or materials, any part or parts which shall be determined to be defective by W-W Grinder Inc. after examination. Commercial use warranty is for a period of ninety (90) days from the date of purchase. In addition, we warrant the cast iron mainframe (except for Tomahawk models) for a lifetime under the same conditions. In the event of a defect or malfunction during this warranty, the purchaser is to return the part to W-W Grinder Inc., 2957 North Market, Wichita, Kansas 67219. All transportation costs on parts submitted for replacement under this warranty must be borne by the purchaser. This warranty presumes

reasonable care of the products by the purchaser and does not cover misuse, abuse, neglect or damage caused by accident.

All motors, engines, tires, bearings or other component parts furnished with this product but not manufactured by W-W Grinder Inc. are covered under this warranty except as modified by the respective manufacturers thereof, whose names and addresses as well as a copy of the warranty provisions to these components will be furnished upon request.

The warranty is made in addition to and not in limitation of the implied warranties of merchantability and fitness for a particular purpose pursuant to the laws of the State of Kansas. Further, this warranty gives you specific legal rights and you may also have other rights which vary from state to state.

SINCE

**W-W GRINDER INC.**

1910

2957 N. Market • P.O. Box 4029 • Wichita, Kansas 67204  
1-316-838-4229  
TOLL FREE 1-800-835-2127

# POINTS OF INTEREST

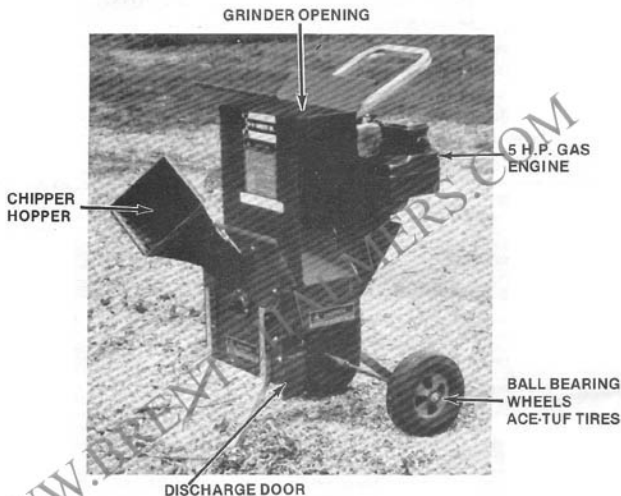

## SPECIFICATIONS

ENGINE	5-8-2		Super Tomahawk G/C	Tomahawk G/M
	Horsepower.....	5.0 Max @ 3600 R.P.M		
Oil Recommended.....	SC, SD, SE, or SF			
Summer (above 32° F.).....	SAE 30 oil			
Winter (below 32° F.).....	SAE 5W20			
Length (Hopper up).....	35"			30"
Length (Hopper down).....	43"			N/A
Width.....	25-1/2"			25-1/2"
Height.....	45"			45"
Weight.....	208 lbs.			162 lbs.
Tires.....	10x4			10x4
Carton Size.....	27½x35x46½			Same
Shipping Weight.....	254 lbs.			174 lbs.

# SAFETY INSTRUCTIONS

## DANGER

DO NOT OPERATE  
WITHOUT WEARING  
SAFETY GLASSES



### BEFORE STARTING

- Become familiar with the owner's manual before attempting to operate your Chipper/Grinder.
- Obtain and wear approved safety glasses and work gloves at all times while operating your Chipper/Grinder.
- Obtain and wear approved safety glasses and work gloves at all times while operating your Chipper/Grinder.
- Wear proper work apparel. Avoid loose-fitting clothing, jewelry, etc. It is preferable to roll up long sleeves and wear snug-fitting work gloves.
- It is recommended to wear hearing protection.
- Before starting the Chipper/Grinder, check that all screws, nuts, bolts, and other fasteners are properly secured. After approximately one hour of operation, recheck all nuts, bolts, screws, and fasteners.
- Before starting the Chipper/Grinder, make sure that the cutting chamber is empty.

### THINGS TO AVOID IN OPERATING

- Do not allow children to operate your Chipper/Grinder.
- Carbon monoxide is extremely dangerous in enclosed areas. Do not run the Chipper/Grinder in an enclosed area because the exhaust from the engine contains carbon monoxide, which is a colorless, odorless, tasteless, and poisonous gas.
- Do not operate this Chipper/Grinder in the vicinity of bystanders.
- Do not operate the Chipper/Grinder on a paved or gravel surface.
- Do not stand in front of the discharge area when operating this Chipper/Grinder.
- Do not put your face and body in front of the feed opening.

### SAFETY MINDED MAINTENANCE AND STORAGE OF YOUR CHIPPER/GRINDER

- When your Chipper/Grinder is stopped for servicing, inspection, or storage, or to change an accessory, make sure the spark plug wire is disconnected from the spark plug. Allow the Chipper/Grinder to cool before making any inspections, adjustments, etc. Maintain the Chipper/Grinder with care and keep it clean.
- Store the Chipper/Grinder out of reach of children and where gasoline vapors will not reach an open flame or

spark. For storage, drain off the gasoline and dispose of it in a safe manner. Always allow the Chipper/Grinder to cool before storing.

### OPERATIONAL SAFETY FOR YOUR CHIPPER/GRINDER

- Do not allow hands or any other part of the body or clothing inside the feed hopper, discharge opening, or near any moving parts.
- Before inspecting or servicing any part of the Chipper/Grinder, shut off the engine, disconnect the spark plug wire from the spark plug and make sure that all moving parts have come to a complete stop.
- When feeding shreddable material into the Chipper/Grinder, be extremely careful that pieces of metal, rocks, bottles, cans, or other foreign objects are not included.
- If the cutting mechanism strikes any foreign object or if the Chipper/Grinder should start making an unusual noise or vibration, immediately shut off the engine and allow the Chipper/Grinder to stop. Disconnect the spark plug wire from the spark plug and take the following steps:

- (1) Inspect for damage.
- (2) Check for and tighten any loose parts.
- (3) Replace or repair any damaged parts.

- Do not let the engine get clogged with debris and other accumulations.
- Do not allow processed material to build up in the discharge area; this may prevent proper discharge and can result in kickback of material through the feed opening.
- Keep all guards, screens, and deflectors in place and in good working condition.
- Do not overreach. Keep proper balance and footing at all times.
- Do not tamper with the engine governor setting on the engine. The governor controls the maximum safe operating speed and protects the engine and all moving parts from damage caused by overspeed.
- Do not transport this Chipper/Grinder while the engine is running.
- If the Chipper/Grinder becomes clogged, shut off the engine and disconnect the spark plug wire before cleaning debris. Use only a wooden stick to clear.
- Do not put hands in the screen area while the Chipper/Grinder is running.

# GENERAL OPERATING INFORMATION

## FEEDING YOUR CHIPPER/GRINDER

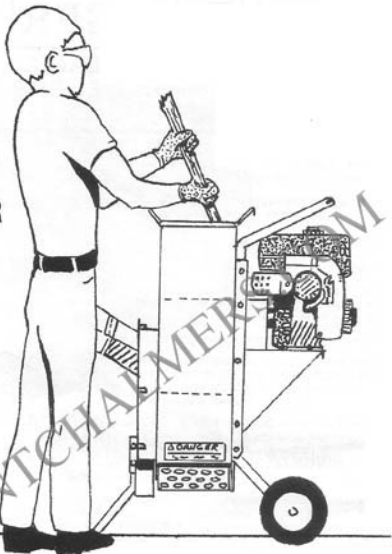

Your Chipper/Grinder is designed for safe, efficient operation. Care, of course, must be exercised so that hands are kept away from the hammers.

Feed the material from the left or right of the Chipper/Grinder so that it slides down the sides of the hopper. A steady flow of material provides the best results.

The rate of feed can be controlled by holding on to the material until it becomes too short to extend past the top of the hopper. At this point, let go of the material and it will feed itself. *NOTE:* The grinder has a tendency to pull long material out of your hand, so don't hold on too tightly.

Under certain conditions, it may be necessary to push the material into the hopper. When this becomes necessary, use a small diameter stick—**NOT YOUR HANDS**. The stick should be of a size that will be ground up if it gets into the cutting area.

The shredded material will be discharged through the screen. Keep clear of this outlet since the shredded material may come out with considerable velocity. Occasionally, when grinding wet material, a buildup will occur at the screen. Grind some dry material to keep the discharge open. It is desirable to have some dry material available for shredding. It is recommended to feed dry refuse alternately with green material and ending with dry material for its self-cleaning action.

The mesh size of the outlet screen largely determines the fineness of the Chipper/Grinder output. The standard screen installed in the machine has 3/4" holes. Screens with smaller holes are available, for grinding corn into feed for livestock or for making potting soil, etc. For wet material, use the optional grid.

# GENERAL OPERATING INFORMATION (Cont.)



LEFT RIGHT

Your safety is our utmost consideration, so please read and heed the following safety rules.

## HELPFUL OPERATING REMINDERS

- It is in your own best interest to obtain and wear safety glasses and gardening or work gloves at all times while operating this Chipper/Grinder.
- Your Chipper/Grinder is a powerful machine. **Children should not operate it nor be near it.**
- Your Chipper/Grinder should never be operated on cement, blacktop, or gravel; only on a level earthen surface.
- Wear work clothes; try not to wear loose-fitting clothing.
- Do not operate your Chipper/Grinder in an enclosed area. The engine exhaust contains carbon monoxide, an odorless, colorless, tasteless, poisonous gas.
- The feed hopper and discharge door are hazardous areas; keep hands and face away.
- The rubber shield inside the chipper helps prevent fly-back. It should never be removed.
- Rocks, metal, cans, glass, or other non-wooden materials are hazardous when fed into your Chipper/Grinder, so take care not to allow these materials in your Chipper/Grinder.
- Ground material should not be allowed to accumulate under the Grinder's discharge opening.
- All guards should remain in place at all times.
- Stand to the side of your Chipper/Grinder, and away from the discharge area.
- Bounce-back from the feed hopper may occur, so keep face and body away from it.
- Keep your balance and footing; never overreach.
- Turn your Chipper/Grinder off before moving it.
- Avoid fire or explosion; fuel only a cooled engine, not warm, hot, or running.
- For best results, feed branches larger than 1/2" in diameter into the *Chipper* hopper.
- Listen to engine RPM. If RPM decreases, pause to allow engine RPM to build back up.
- Feed dry materials with wet (or alternately) to help stop clogging.
- The bearings are sealed ball bearings, so they require no oil or grease.
- More wooded material can be ground faster when it is fed evenly and smoothly, so don't overload.

## HOW YOUR CHIPPER/GRINDER WORKS

Organic material is initially broken and shredded when the cylinder hammers force it against the Chipper/Grinder main frame. Additional shredding occurs as the material is carried across the screen by the cylinder hammer, discharging through the screen. The Chipper cuts limbs by a knife and anvil. Chips are discharged through the discharge door.

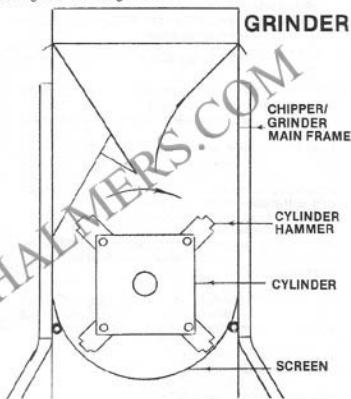

## CHIPPER ASSEMBLY

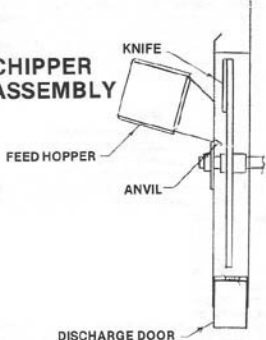

# GENERAL OPERATING INFORMATION (Cont.)

When clogs occur at the screen, stop the machine and remove one of the screen rods. Material will spill out onto the ground when you turn the cylinder by pushing with a stick. Remember to be sure to disconnect the spark plug wire before clearing the screen.

The raw materials that are used for compost can be classified into three categories:

1. Dry, lightweight material—leaves, grass, clippings, straw.
2. Wet material—manure, wet leaves, garbage, partially finished compost.
3. Bulky materials—stalks, vines, small branches.

Feed the machine slowly until you are familiar with its operation. Keep your hands away from the cylinder by using a fork or shovel to feed into the hopper. Long, stringy vines can be fed in by using a thin soft-wood board. Sod, heavy sod or heavy soil should slide down the hopper gradually to prevent choking. Friable material can be fed into the cylinder more rapidly. Materials and conditions vary greatly. By being patient you will soon know how to process any material.

The full-width hopper is for use on all friable material. Large diameter shrubs and tree trimmings should be fed into the chipper hopper.

Do not let the ground material pile build up against the bottom of the screen.

The perforated screen is in place when shipped. Unless otherwise specified, we have furnished a perforated screen with 3/4" holes. This screen is generally best for making compost. Wet, gummy material should never be run through this screen, as it will clog up the holes. Use the grid screen when a coarser grind is desired on your finished compost. *NOTE: The screen is held by two rods.*

## CHIPPER

Your Chipper/Grinder will chip branches up to 3" in diameter through the chipper hopper (3" is the maximum diameter, depending on the type of wood). To reduce branches to small chips, simply insert the branch into the chipper hopper. Stand to the side of the chipper hopper and keep the branch away from your body to avoid any bounce-back of the branch. Hold the branch firmly to keep it from twisting in your hands.

Push firmly until the branch is reduced to the length of the hopper. Pay close attention to the chipper's RPM. If the chipper slows down, reduce pressure on the feed and let the unit build speed back up, then continue. (Never allow your hands into the chipper hopper.) Short stubs of branches may be pushed

through the chipper section with the next branch.

Green branches, or tough, sinewy wood such as mulberry, should be evenly rotated as they are fed into the chipper. This will help to prevent the bark from stringing out and wrapping around the shredding drum shaft.

The chipper hopper is hinged so that it can be raised to reduce storage space requirements.

Never assume you know where the blade is, and try to push short branches through by hand. You don't know where it is. Be safe, keep your hands away from the chipping blade.

## OPERATING TIPS

Soil particles are abrasive and will dull the cutting edges. For longest cutter life it is best to use primarily clean refuse. Heavier branches and twigs should be chipped as soon as possible after cutting. Green wood is easier than dry. **ROTATING THICK BRANCHES SLIGHTLY MAKES IT EASIER.**

Very green or wet refuse and waste material may stick to the sides of the feed hopper or discharge chute. It is preferable to let such material dry for a few days.

It is desirable to have some dry material available for shredding. It is recommended to feed dry refuse alternately with greener material and ending with dry material for its self-cleaning action. Plants and weeds bearing viable seeds should not be shredded for mulching application, but only for composting.

Timely changing of cutting edges makes the job much easier.

## CENTRIFUGAL CLUTCH

Your Chipper/Grinder is equipped with a centrifugal clutch. Particular care should be taken to prevent overloading the shredding drum. When the engine is running at full RPM, the drum can be stalled by too much material, making the clutch slip. This slippage will generate excessive heat in the clutch which may cause damage.

## GASOLINE ENGINE

 Your gasoline engine is shipped without oil in the crankcase or fuel in the tank. Fill before starting the engine, following the engine manufacturer's specifications and recommendations as to type of oil and fuel.

Do not tamper with the engine governor settings on the machine. The governor controls the maximum safe operating speed and protects the engine and all moving parts from damage caused by overspeed.



# UNCRATING & ASSEMBLY INSTRUCTIONS

1. Cut bands.
2. Carefully cut around bottom of box.
3. Cut remaining band holding down Chipper/Grinder handle
4. Remove bracket from front stand.
5. Assemble handle using hardware as shown.

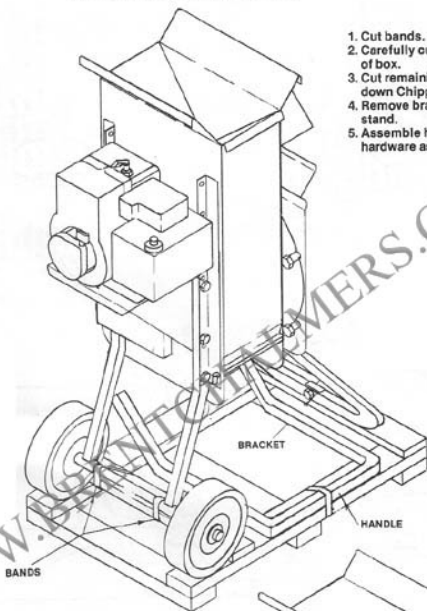

1. Chipper/Grinder assembly
2. Handle
3. Hex head cap screw GR 5/16" - 18 x 1-1/2
4. Whiz nut 5/16" - 18

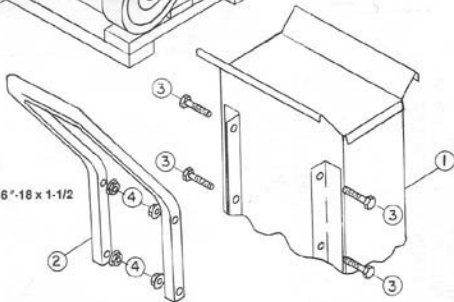

**SUPER TOMAHAWK**  
**5-2-8G/C DRAWING ONE**  
 UNIT IS UPSIDE DOWN  
 REMOVE GAS AND OIL FROM  
 ENGINE IF ASSEMBLED

**PARTS LIST 5-8-20JC SUPER TOMAHAWK**  
**DRAWING ONE**

Ref. No.	Part No.	Description	Qty.
1	2050-900	Grinder Main Frame Assy, Super Tomahawk	1
2	2030-903	Cyl. Shaft Super Tomahawk	1
3	2030-900-1	Chipper Disc, Assy, (less knife)	1
4	2030-901	Chipper Knife	1
5	2030-750	Cyl. Assy.	1
6	AX-145P	Bearing-Flangette 52MS	2
7	RA100RRB	Bearing-1 inch w/collar	1
8	BC40X1	Pulley	1
9	06-273	Keystock 1/4 x 1/4 x 1-1/4	1
10	0235-0513	Hex Head Cap Screw GR5 J/8-16 x 1-3/4	2
11	0235-0503P	Carriage Bolt 5/16-18 x 3/4	3
12	0226-0403P	Rat Head Allen Screw 1/4-20 x 3/4 Allen Head	3
13	0310-006P	Locknut 2 way 3/8-16P	2
14	0335-026P	Whiz Nut 5/16-18P	3
15	355	Midwest conduit Plug 112	1

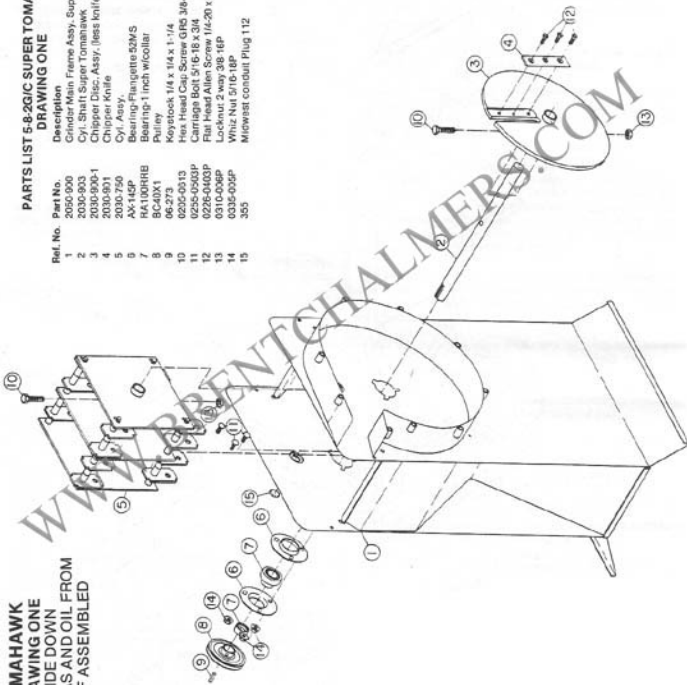

**SUPER TOMAHAWK**  
**5-8-2G/C DRAWING TWO**  
**UNIT IS UPSIDE DOWN**  
**REMOVE GAS AND OIL FROM**  
**ENGINE IF ASSEMBLED**

**PARTS LIST 5-8-2G/C SUPER TOMAHAWK**  
**DRAWING TWO**

Ref. No.	Part No.	Description	Qty.
0	AX-145P	Bearing-Flangette S2MS	2
7	HA100RRB	Bearing-1 in. w/Collar	1
11	0255-0503P	Carrage Bolt 5/16-18 x .34	3
14	0335-005P	Whiz Nut 5/16-18	11
15	2050-902	Slide Plate Assy., Chipper	1
16	2050-759	Grinder Main Frame Screen Assy. .34	1
17	2052-761	Grinder Main Frame Screen Rod	2
18	0205-0512P	Hex Head Cap Screw GR5 5/16-18 x 1-1/2	8
19	0335-004P	Whiz Nut 1/4-20	1
20	311-502	No. 3 Hair Pin Clip	2

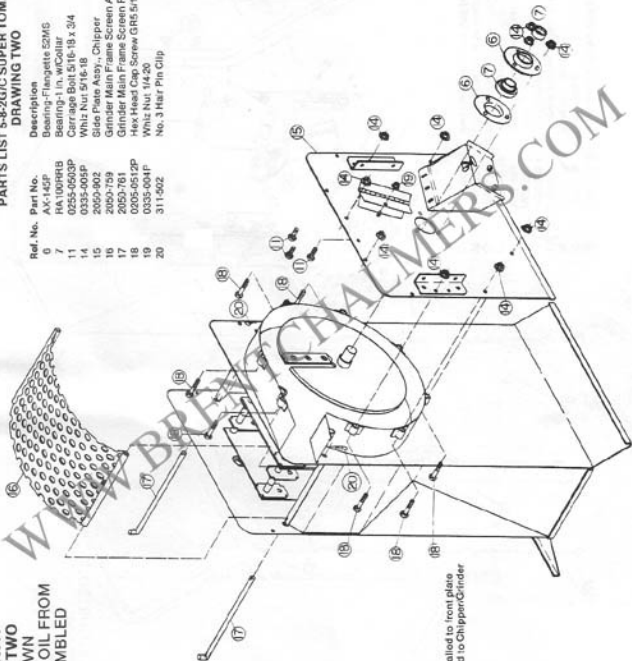

NOTE: Bearing must be installed to front plate before front plate is installed to Chipper/Grinder

**SUPER TOMAHAWK**  
**5-8-2G/C DRAWING THREE**  
**UNIT IS UPSIDE DOWN**  
**REMOVE GAS AND OIL FROM**  
**ENGINE IF ASSEMBLED**

**PARTS LIST 5-8-2G/C SUPER TOMAHAWK**  
**DRAWING THREE**

Ref. No.	Part No.	Description	Qty.
14	0335-005P	Whiz Nut 5/16-18	7
18	0205-0512P	Hex Head Cap Screw GR5 5/16-18 x 1-1/2	6
21	2050-754	Front Stand	1
22	2000-750	Axle Brkt. Assy.	2
23	2050-806	Chipper Discharge Door Assy.	2
24	2000-900-1	Axle Spacer	2
25	2000-900	Axle	2
26	SPW-204	Plastic Wheel 10X4 off-set	2
27	PW625019	Pushnut, Fastener	2
28	9005K23	Plastic Plug	4
29	2050-906-3	Chipper Discharge Door Spring	1
30	0205-0512P	Hex Head Cap Screw GR5 5/16-18 x 3-1/2	1

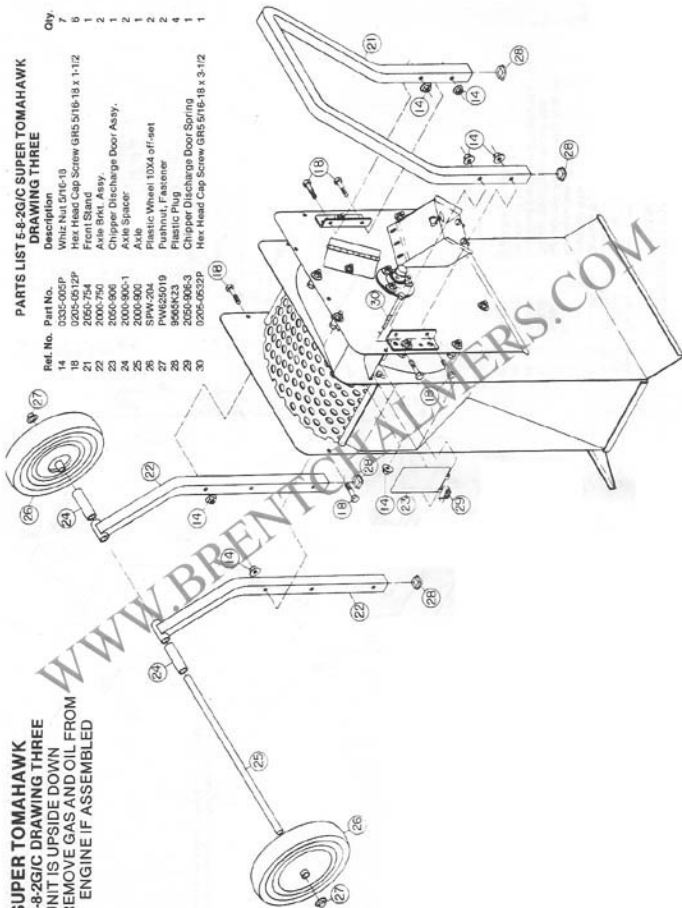

**SUPER TOMAHAWK**  
**5-8-2G/C DRAWING FOUR**  
 UNIT IS UPSIDE DOWN  
 REMOVE GAS AND OIL FROM  
 ENGINE IF ASSEMBLED  
 LEAVE ALL BOLTS LOOSE  
 UNTIL ENGINE IS ADJUSTED

**PARTS LIST 5-8-2G/C SUPER TOMAHAWK**  
**DRAWING FOUR**

Ref. No.	Part No.	Description	Qty.
14	0335-006P	Whiz Nut 5/16-18	8
31	0205-0530A	Hex Head Cap Screw GR5 5/16-18 x 3 (All Thread)	2
32	2090-801	Motor Plate Assy.	1
33	0350-006	Accrn Nut 5/16-18	2
34	0205-0513P	Hex Head Cap Screw GR5 5/16-18 x 1.3/4	4
35	0420-006P	Flatwasher 5/16	4

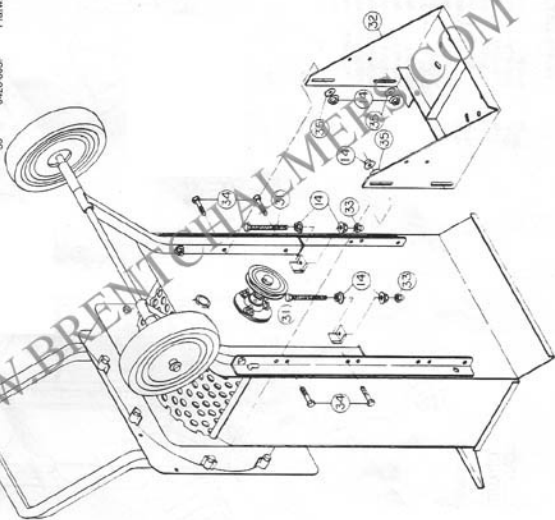

# SUPER TOMAHAWK

## 5-8-2G/C DRAWING FIVE

DO NOT INSTALL BELT GUARDS  
UNTIL ENGINE IS ADJUSTED

1-1/2 BOLTS (18) FOR

BRIGGS & STRATTON ENGINE

3/4 BOLTS (44) FOR

TECUMSEH ENGINE

# PARTS LIST 5-8-2G/C SUPER TOMAHAWK

## DRAWING FIVE

Ref. No.	Part No.	Description	Qty.
14	0305-006P	Whiz Nut 5/16-18	8
18	0205-0512P	Hex Head Cap Screw CR5 5/16-18 x 1-1/2	8
19	0305-004P	Whiz Nut 1/4-20	6
36	130232-1536-01	5 H.P. Gas Engine—B & S	1
36	150-65484N	5 H.P. Gas Engine—Tecumseh	1
37	912-F408-71-0	Cutch 3/4 Bore Outboard Mt.	1
38	2050-753	Handle	1
39	5L350	V-Belt	1
40	2050-762	Restrainer Flap	1
41	2010-750	Belt Guard Upper	1
42	2010-751	Belt Guard Lower	1
43	0205-0402P	Hex Head Cap Screw 1/4-20 x 1/2	6
44	0205-0503P	Hex Head Cap Screw 5/16-18 x 3/4	6
45	0272-0403P	Pan Head PH Self Tapping 1/4 x 3/4	4
46	06-274	Keysloch 3/16 x 1/16 x 1-1/4	2
48	0465-904P	1/4 Lockwasher	2

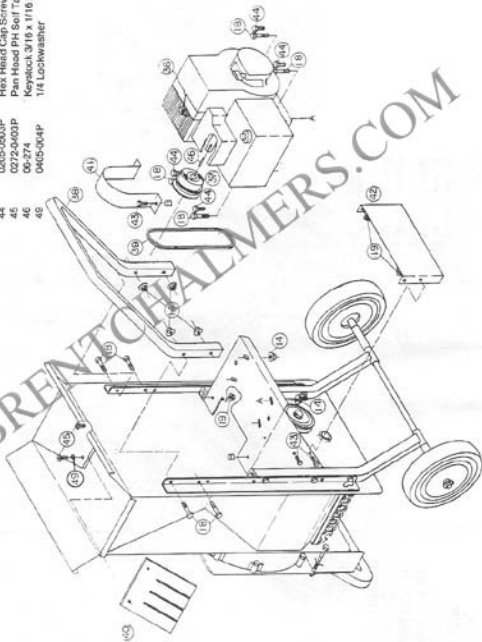

**SUPER TOMAHAWK  
5-8-2G/C DRAWING SIX  
CHIPPER HOPPER**

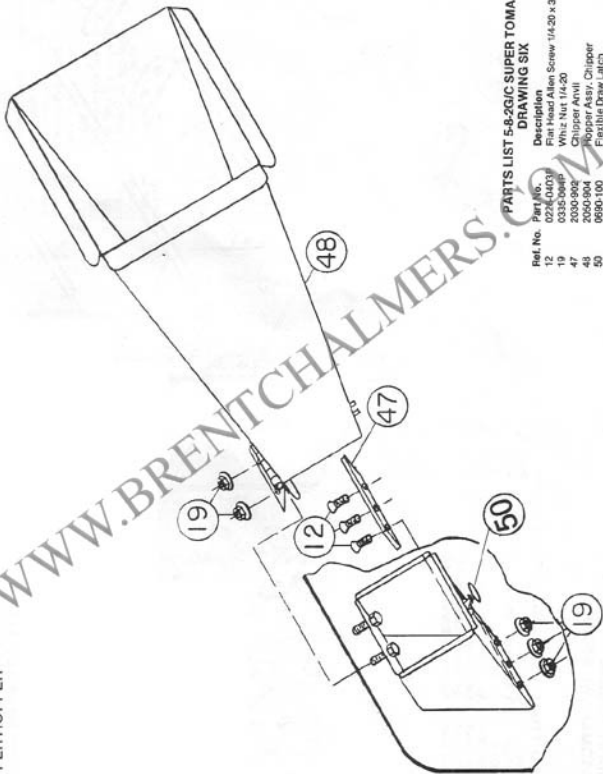

**PARTS LIST 5-8-2G/C SUPER TOMAHAWK  
DRAWING SIX**

Part No.	Description	Qty.
12	0224-0403 Flat Head Allen Screw 1/4-20 x .34 Alien Head	3
19	0335-094P Whit Nut 1/4-20	3
47	2030-902 Chipper Anvil	1
48	2050-904 Hopper Assy, Chipper	1
50	0690-100 Flexible Draw Latch	1

**CYLINDER ASSEMBLY  
TOMAHAWK 5-8-2G/M  
SUPER TOMAHAWK 5-8-2G/C**

**PARTS LIST FOR CYLINDER ASSY. 5-8-2G/M & 5-8-2G/C**

Ref. No.	Part No.	Description	Qty.
1	311-503	Cotter Pin 1/8 x 1-1/4	6
2	2036-751	Cyl. 8-2	1
3	2036-750-2	Cyl. Pin 8-2	4
4	2036-750-3	Cyl. Hammer 8-2	16
5	2036-750-4	Cyl. Hammer Spacer Long 8-2	16
6	2036-750-5	Cyl. Hammer Spacer short 8-2	6

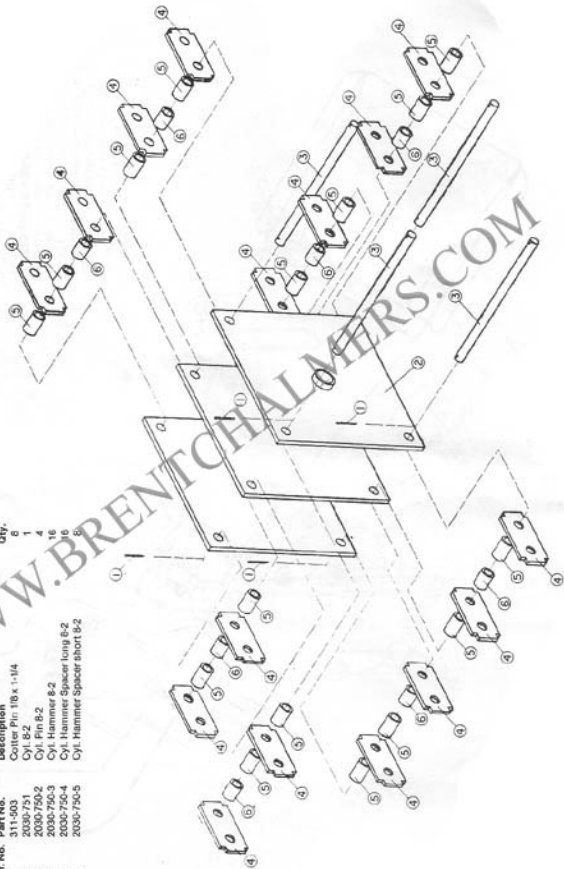



# TOMAHAWK

## 5-8-2G/M DRAWING ONE

UNIT IS UPSIDE DOWN  
REMOVE GAS AND OIL FROM  
ENGINE IF ASSEMBLED  
BEARING MUST BE INSTALLED  
BEFORE CYLINDER IS INSTALLED

## PARTS LIST 5-8-2G/M TOMAHAWK DRAWING ONE

Ref. no.	Part No.	Description	Qty.
1	2050-800	Grinder Main Frame Assy, Tomahawk	1
2	2030-750-1	Cyl. Shaft	1
5	2030-750	Cyl. Assy.	1
6	AX-145	Bearing-Flangeite 50MS	4
7	RA100RRB	Bearing-1 in. w/Collar	2
8	BC40X1	Pulley	1
9	06-273	Keystock 1/4 x 1/4 x 4 1/4	1
10	0205-0813	Hex Head Cap Screw GFS 3/8-16 x 1-3/4	1
11	0255-0503P	Carriage Bolt 5/16-18 x 3/4	1
13	0310-005LP	Locknut 2-WAY 3/8-16	6
14	0335-005EP	Whiz Nut 5/16-18	1
15	355 Midwest	Conduit Plug 1/2	2

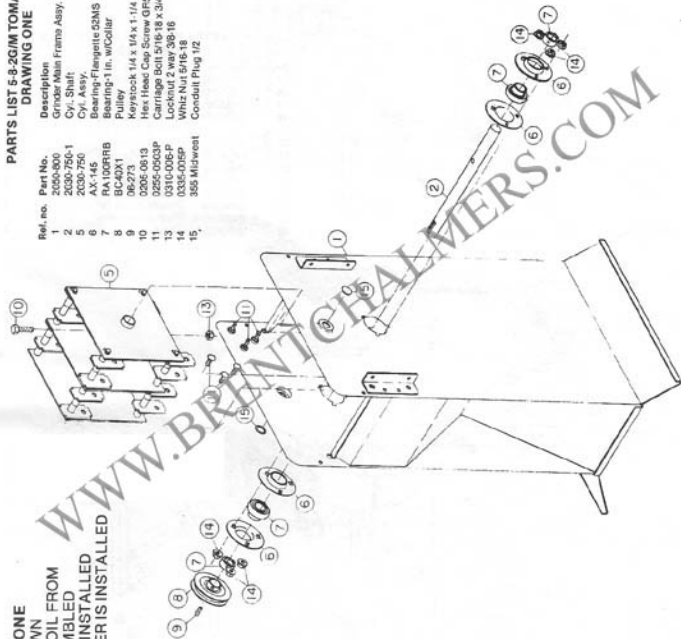

**TOMAHAWK**  
**5-8-2G/M DRAWING TWO**  
 UNIT IS UPSIDE DOWN  
 REMOVE GAS AND OIL FROM  
 ENGINE IF ASSEMBLED

**PARTS LIST 5-8-2G/M TOMAHAWK  
 DRAWING TWO**

Ref. No.	Part No.	Description	Qty.
14	0335-005P	Whiz Nut 5/16-18	6
16	2050-759	Screen Assy. 3/4	1
17	2050-761	Screen Rod	2
18	0205-0512P	Hex Head Cap Screw GR5 5/16-18 x 1-1/2	6
20	311-502	No. 3 Hair Pin Clip	2
21	2050-754	Front Stand	1
22	2000-750	Axle Brkt. Assy.	2
24	2000-900-1	Axle Spacer	2
25	2000-900	Axle	1
26	SPW-204	Plastic Wheel 10X4 Off-set	2
27	PW625019	Washer Fastener	2
28	9566K22	Plastic Plug	4

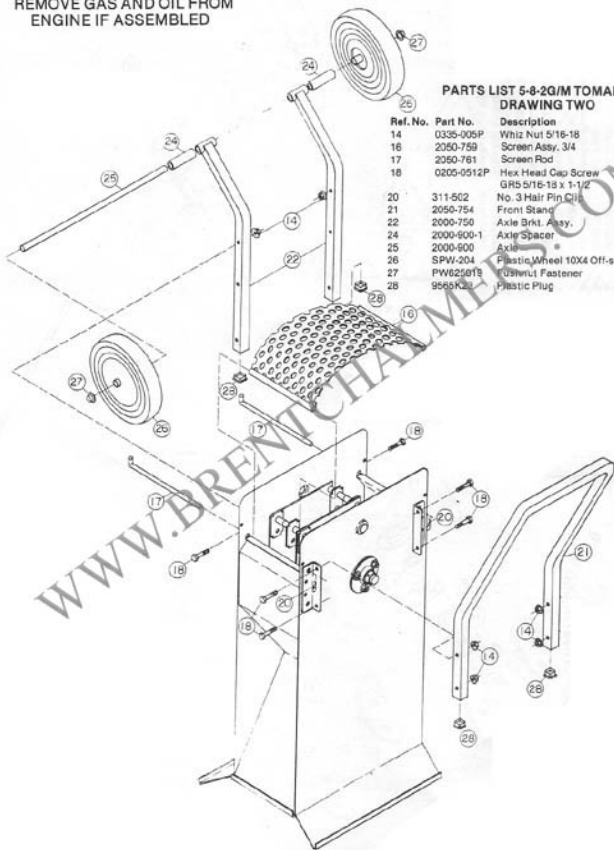

**TOMAHAWK**  
**5-8-2G/M DRAWING THREE**  
 UNIT IS UPSIDE DOWN  
 REMOVE GAS AND OIL FROM  
 ENGINE IF ASSEMBLED

**PARTS LIST 5-8-2G/M TOMAHAWK**  
**DRAWING THREE**

Ref. No.	Part No.	Description	Qty.
14	0335-005P	Whiz Nut 5/16-18	8
31	0205-0530A	Hex Head Cap Screw GRS 5/16-18 x 3 (All Thread)	2
32	2090-801	Motor Plate Assy.	1
33	0350-005	Acorn Nut 5/16-18	2
34	0205-0513	Hex Head Cap Screw GRS 5/16-18 x 1-3/4	4
35	0420-005P	Flat Washer 5/16	4

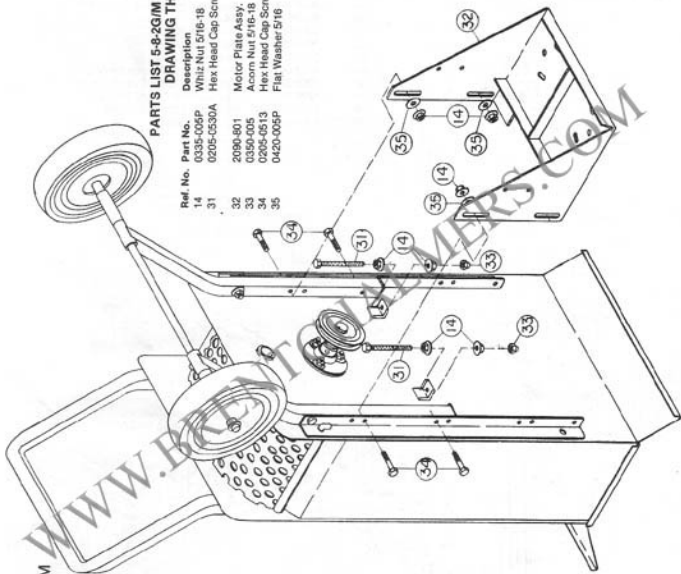

# TOMAHAWK

## 5-8-2G/M DRAWING FOUR

DO NOT INSTALL BELT GUARDS

UNTIL ENGINE IS ADJUSTED

1-1/2 BOLTS (18) FOR

BRIGGS & STRATTON ENGINE

3/4 BOLTS (44) FOR

TECUMSEH ENGINE

## PARTS LIST 5-8-2G/M TOMAHAWK

### DRAWING FOUR

Ref. No.	Part No.	Description	Qty.
14	0335-005P	Whiz Nut 5/16-18	8
18	0205-0512P	Hex Head Cap Screw GR5 5/16-18 x 1-1/2	8
19	0335-004P	Whiz Nut	6
36	130232-1536-01	5 H.P. Gas Engine—B & S	1
36	H50-65484N	5 H.P. Gas Engine—Tecumseh	1
37	912-P40B-71-0	Clutch 3/4 Bore Outboard Mt.	1
38	2050-753	Handle	1
39	5L350	V-Belt	1
40	2050-762	Restrainer Flap	1
41	2010-750	Belt Guard Upper	1
42	2010-751	Belt Guard Lower	1
43	0205-0402P	Hex Head Cap Screw 1/4-20 x 1/2	6
44	0205-0503P	Hex Head Cap Screw 5/16-18 x 3/4	4
45	0272-0403P	Panhead P.H. Selftap 1/4 x 3/4	2
46	06-274	Keystock 3/15 x 3/16 x 1-1/4	1
49	0405-004P	1/4 Lockwasher	2

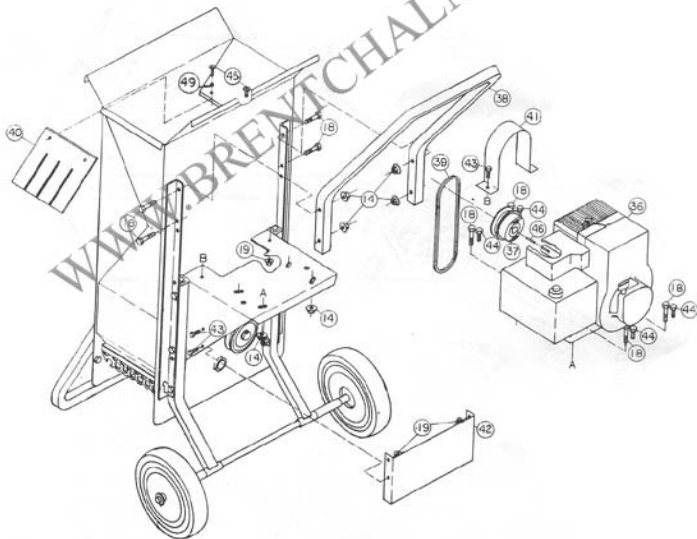

# MAINTENANCE TIPS

## I. How to Change Hammers

Tools required:  
 Flat Head Screwdriver  
 Needle Nose Pliers — 2 each

- Remove one plug from Grinder/Chipper Main Frame as shown in Figure 1
- Hold Cylinder Pin with pliers and remove cotter pin at other end of pin as shown in Figure 2

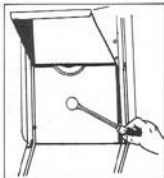

Fig. 1

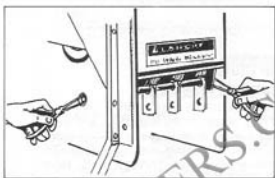

Fig. 2

- Pull out Cylinder Pin from Cylinder
- Replace Hammers and Spacers as shown in Figures 3A and 3B
- Replace Cotter Pins
- Repeat steps 2 through 5 on remaining Cylinder Hammers.

NOTE: Rows 1 & 3 are the same  
 Rows 2 & 4 are the same

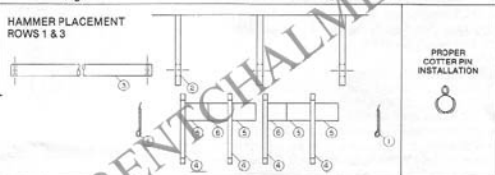

Fig. 3A

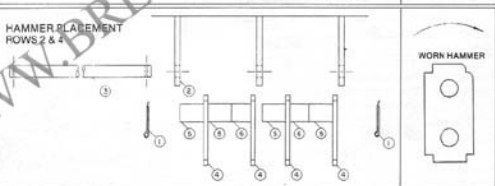

Fig. 3B

NOTE:  
 See Page 16  
 for close-up  
 view and parts  
 identification.

## II. Removal and Sharpening of Chipper Knife

Tools required:  
 7/16 Wrench, box or open.  
 5/32 Allen Wrench

- Remove whiz nut from knife access door as shown in Figure 4
- Turn Cylinder until knife is viewable through access door
- Remove knife with allen wrench
- Sharpen at a 45-degree angle as shown in Figure 5
- Install knife
- Close knife access door and replace whiz nut

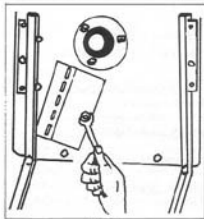

Fig. 4

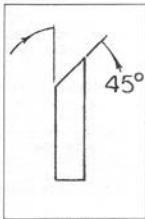

Fig. 5

### III. Engine Adjustment and Belt Tension

Tools required:  
Straight Edge  
5/16 Open End Wrench — 2 each

- Remove Upper and Lower Belt Guards
- Loosen bottom whiz nut a few turns
- Hold top whiz nut and turn all thread bolt as shown in Figure 6 until belt is at desired tension (see Figure 7)
- Tighten bottom whiz nut holding bolt so it does not turn.
- Reinstall upper and lower belt guards

**NOTE:** Do not run Chipper Grinder with belt guards off.

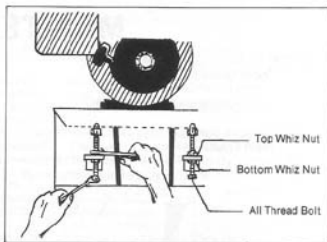

Fig. 6

### IV. Centrifugal Clutch Care

#### A. Disassembly and Reassembly

When removing clutch from shaft, loosen setscrews first. Avoid hammers or pinch bars which may distort drum. Save key. Slide drum off rotor after removing retaining ring. To avoid nicking or cutting springs, wrap tape around tines of pliers. When hanging springs, avoid overextending. Replace worn or missing washers. Reassemble drum to rotor, secure retaining ring. Set key. Slide clutch onto shaft. Align pulley or sprocket. Tighten setscrews (see Figure 8.)

#### B. Lubrication and Maintenance

Oilite brushing models use SAE 30 oil. Apply several drops in area of retaining ring directly after use. Ball and needle bearings may be cleaned in mineral spirits before lubricating with a lithium or moly-base grease. If drum wobbles, replace bushing (or bearing); if tips of set screws are flat or crushed, replace. Replace shoes and springs in pairs. Use new springs when replacing worn shoes.

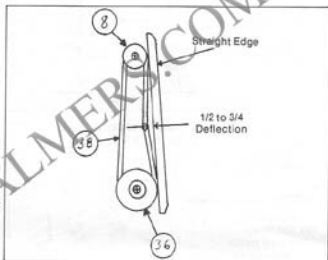

Fig. 7

Ref. No.	Part No.	Description	Qty.
1	011-002	Clutch Setscrew	1
2	018-076	Clutch Snap Ring	1
3	024-068	Clutch Plastic Washer	1
4	017-018	Clutch Bushing	1
5	116-719	Clutch Drum	1
6	010-020	Clutch Spring — red	2
7	112-159	Clutch Shoe	2
8	113-216	Clutch Hub	1

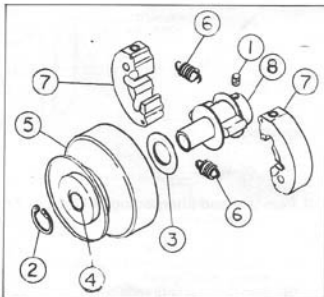

Fig. 8

**V. It is advisable to make a periodic check of all bolts, nuts and screws.**

### VI. Storage of your Chipper/Grinder

- The Chipper/Grinder will fit into an area about the size of a lawnmower.
- Be sure to drain all oil and gas before storage.
- The Hopper is hinged to make storage simpler
- Store away from children.

# OWNER'S INFORMATION

Briggs & Stratton

## BEFORE STARTING

### READ THE OPERATING INSTRUCTIONS OF THE EQUIPMENT THIS ENGINE POWERS

Use a high quality detergent oil classified "For Service SF, SE, SD or SC." Detergent oils keep the engine cleaner and retard the formation of gum and varnish deposits. Nothing should be added to the recommended oil.

### RECOMMENDED SAE VISCOSITY GRADES

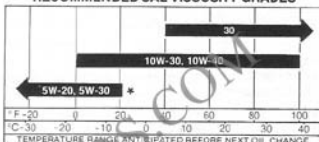

\*If not available, a synthetic oil may be used having 5W-20, 5W-30 or 5W-40 viscosity.

### TO FILL CRANKCASE WITH OIL

Place engine level. Clean area around oil fill before removing oil fill plug or oil minder.

**OIL FILL PLUG** Remove oil fill plug or (optional) oil-minder. Fill crankcase to point of overflowing. **POUR SLOWLY.** Capacity approximately 1¼ pints (0.59 liters). Replace oil fill plug or oil-minder.



**EXTENDED OIL FILL (OPTIONAL)** Remove cap and dipstick. Fill to full mark on dipstick, **POUR SLOWLY.** Capacity approximately 1¼ pints (0.59 liters). When checking oil level, screw dipstick assembly firmly but slowly until cap bottoms on tube. **Do not overfill.** Dipstick assembly must be securely assembled to tube at all times when engine is operating.

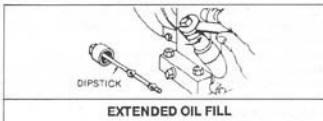

### FILL FUEL TANK

Use clean, fresh, "regular grade leaded, low-lead or lead-free" gasoline. **Do not mix oil with gasoline.**

**NOTE:** The use of "lead-free" gasoline produces fewer combustion deposits, but may shorten valve life if carburetor adjustment is too lean.

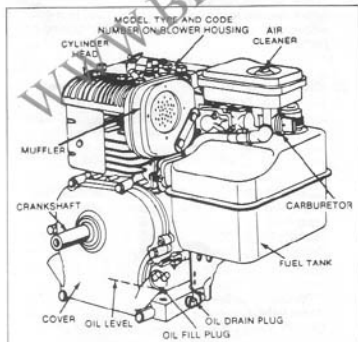
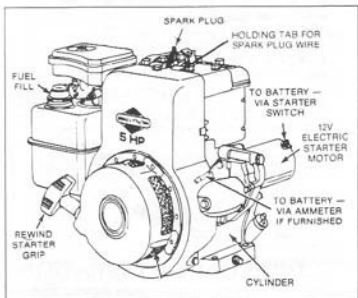

# Briggs & Stratton

## STARTING

Start, store and fuel engine in a level position.

**CHOKE ENGINE** — Engine may be equipped with either Manual, Choke-A-Matic or Lever-Trol controls.

**MANUAL CHOKE:** Pull choke as illustrated.

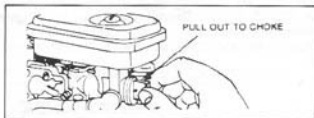

### TO START ENGINE

**DANGER:** Always keep hands and feet clear of rotating machinery.

Rewind starter. Grasp starter handle as illustrated and pull out cord rapidly to overcome compression and prevent kickback. Repeat if necessary with choke opened slightly. When engine starts, open choke gradually.

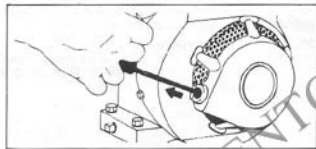

## ADJUSTMENTS

### CARBURETOR ADJUSTMENTS

Minor carburetor adjustment may be required to compensate for differences in fuel, temperature, altitude or load.

**NOTE:** The air cleaner must be assembled to carburetor when running engine.

**TO ADJUST CARBURETOR** — Gently turn needle valve clockwise until it just closes. Valve may be damaged by tuning it in too far.

Next, open the needle valve 1-1/2 turns counterclockwise. This initial adjustment will permit the engine to be started and warmed up (approximately 5 minutes) prior to final adjustment.

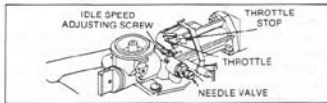

### FINAL ADJUSTMENT

Place speed control lever in "Fast" position. Turn needle valve in until engine slows (clockwise—lean mixture). Then turn it out past smooth operating point until engine runs unevenly (rich mixture). Now turn needle valve to the midpoint between rich and lean so the engine runs smoothly. Next, adjust idle RPM. Rotate throttle counterclockwise and hold against stop. Adjust idle speed adjusting screw to obtain 1750 RPM. Release throttle—engine should accelerate without hesitation or sputtering. If engine does not accelerate properly, the carburetor should be re-adjusted, usually to a slightly richer mixture.

### STANDARD SPEED CONTROL ADJUSTMENT

Speed adjusting thumb nut is located on top of engine. To increase speed, turn thumb nut clockwise.



## GENERAL INFORMATION

These engines are single-cylinder L-head, air-cooled type.

### MODEL SERIES 130200 to 131299

Bore.....	2.9/16" (65.09 mm)
Stroke.....	2.7/16" (61.91 mm)
Displacement.....	12.57 cu. in. (206.0 cc)
Horsepower.....	5.0 Max @ 3600 RPM
Torque (Ft. Lbs.).....	7.66 Max. @ 3000 RPM

The horsepower ratings listed are established in accordance with the Society of Automotive Engineers Test Code - J607. For practical operation, the horsepower should not exceed 85% of this rating. Engine power will decrease 3½% for each 1,000 feet (304.8 m) above sea level and 1% for each 10° above 60° F. (16° C).

In some areas, local law requires the use of a resistor spark plug so as to suppress ignition signals. If an engine was originally equipped with a resistor spark plug, be sure to use the same type of spark plug for replacement.

### TUNE-UP SPECIFICATIONS

Spark Plug Type	Champion	Autolite	Robert Bosch
Short Plug	CJ-8	235	WS9E
Long Plug	J-8	295	—
Resistor Short Plug	RCJ-8	245	WSR9E
Resistor Long Plug	RJ-8	306	—
Spark Plug Gap.....	.030" (.76 mm)		
Ignition Point Gap (Model 13020 Series only).....	.020" (.51 mm)		
Intake Valve Clearance.....	.005" - .007" (.13-.18 mm)		
Exhaust Valve Clearance.....	.009"-.011" (.23-.28 mm)		



## MAINTENANCE

**WARNING:** To prevent accidental starting when servicing the engine or equipment, always remove the spark plug wire from the spark plug and insert in holding tab, if so equipped, where shown on page 29. Disconnect battery from starter motor by unplugging wires at the connector.

**CHECK OIL LEVEL** regularly—after each five hours of operation. **Be sure oil level is maintained.**

**CHANGE OIL** after first five hours of operation. Thereafter change every 25 hours of operation. Remove the oil drain plug and drain oil while engine is warm. Replace drain plug. Remove oil fill plug or oil-minder and refill with new oil of proper grade. Replace oil fill plug or oil-minder.

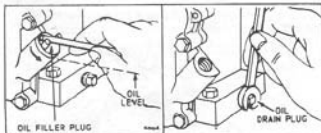

**TO SERVICE AIR CLEANER "OIL FOAM" AIR CLEANER** Clean and re-oil foam element at three-month intervals or every 25 hours, whichever occurs first.

**NOTE:** Service air cleaner more often under dusty conditions.

1. Remove screw.
2. Remove air cleaner carefully to prevent dirt from entering carburetor.
3. Take air cleaner apart and clean.
  - a. Wash foam element in kerosene or liquid detergent and water to remove dirt.
  - b. Wrap foam in cloth and squeeze dry.
  - c. **Saturate foam with engine oil.** Squeeze to remove excess oil.
4. Reassemble parts and fasten to carburetor securely with screw.



**CLEAN COOLING SYSTEM** — Grass, chaff or dirt may clog the rotating screen and the air cooling system, especially after prolonged service cutting dry grass. Yearly or every 100 hours, whichever occurs first, remove the blower housing and clean the areas shown to avoid overspeeding, overheating and engine damage. Clean more often if necessary.

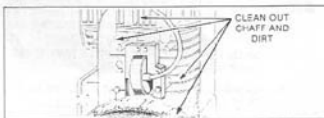

**DANGER** — Periodically clean muffler area to remove all grass, dirt and combustible debris.

**SPARK PLUG** — Clean and reset gap at .030" every 100 hours of operation.

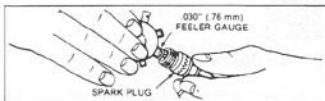

**CAUTION:** Do not blast clean spark plug. Spark plug should be cleaned by scraping or wire brushing and washing with a commercial solvent.

Sparking can occur if wire terminal does not fit firmly on spark plug, or if stop switch vibrates against spark plug. Reform terminal or repair switch if necessary.

**REMOVE COMBUSTION DEPOSITS** every 100-300 hours of operation. Remove cylinder head and cylinder head shield. Scrape and wire brush the combustion deposits from cylinder, cylinder head, top of piston and around valves. Use a soft brush to remove deposits. Reassemble gasket, cylinder head and cylinder head shield. Turn screws down finger tight with the three longer screws around the exhaust valve, if so equipped. Torque cylinder head screws in a staggered sequence to 140 inch pounds (15.82 Nm).

**SPARK ARRESTER EQUIPPED MUFFLER** — If engine muffler is equipped with spark arrester screen assembly, remove every 50 hours for cleaning and inspection. Replace if damaged.

**CLEAN ENGINE** — Remove dirt and debris with a cloth or brush. Cleaning with a forceful spray of water is not recommended as water could contaminate the fuel system.

### STORAGE INSTRUCTIONS

Engines to be stored over 30 days should be completely drained of fuel to prevent gum deposits forming on essential carburetor parts, fuel filter and tank.

**NOTE:** The use of a fuel additive, such as STA-BIL, or an equivalent, will minimize the formation of fuel gum deposits during storage. Such an additive may be added to the gasoline in the fuel tank of the engine, or to the gasoline in a storage container.

- a. All fuel should be removed from the tank. Run the engine until it stops from lack of fuel. The small amount of fuel that remains in the sump of the tank should be removed by absorbing it with a clean, dry cloth.
- b. While engine is still warm, drain oil from crankcase. Refill with fresh oil.
- c. Remove spark plug, pour approximately 1/2 ounce (15 cc) of engine oil into cylinder and crank slowly to distribute oil. Replace spark plug.
- d. Clean dirt and chaff from cylinder, cylinder head fins, blower housing, rotating screen and muffler areas.
- e. Store in a clean and dry area.



# OWNER'S INFORMATION

## TECUMSEH

### OIL & FUEL RECOMMENDATIONS

To start and operate your Tecumseh engine, you will need the following:

- 1 A CLEAN, HIGH QUALITY DETERGENT OIL.** Be sure original container is marked with engine service classification "SC," "SD," "SE" or "SF."  
**DO NOT USE SAE10W40 OIL.**

**FOR SUMMER (ABOVE 32°F) USE SAE 30 OIL.**  
(SAE 10W30 is an acceptable substitute.)

**FOR WINTER (BELOW 32°F) USE SAE 5W20 or 5W30 OIL.** (SAE 10W is an acceptable substitute.)  
**(BELOW 0°F ONLY)** SAE 10W oil diluted with 10% kerosene is acceptable.

Oil Sump capacity is approximately 19 ounces (1-1/8 pints).

- 2 A FRESH, CLEAN, UNLEADED AUTOMOTIVE GASOLINE.** (Leaded "Regular" grade gasoline is an acceptable substitute.)

**NOTE:** Gasahol requires special care when engine is unused for extended periods. See "Storage" Instructions on page 28.

**NOTE:** Use clean oil and fuel and store in approved, clean, covered containers. Use clean fill funnels.

### PRE-START INSTRUCTIONS

- 1** Read all instructions provided with the equipment on which this engine is used.

- 2** **FILL OIL SUMP WITH OIL.** See preceding "Oil & Fuel Recommendations," item 1 for correct oil and Figure 1 for oil fill locations.

**POSITION EQUIPMENT SO ENGINE IS LEVEL.** Remove Oil Fill Plug and Dipstick and place it on a clean surface.

Fill oil sump, slowly, to "full" mark on Dipstick. **Do not overfill.** Oil Fill Plug must be seated fully and tightened and/or locked securely into oil fill hole when checking oil level.

- 3** Oil level should be checked frequently during initial engine break-in period. Oil Fill Plug must be seated fully and tightened and/or locked securely when engine is running.

- 4** **OIL AIR CLEANER FILTER**

If your engine is equipped with a Foam Type Filter proceed as follows:

- Remove Filter per "Service Air Cleaner" instructions on page 27.
- Saturate Filter with engine oil and squeeze to distribute oil and remove excess oil.

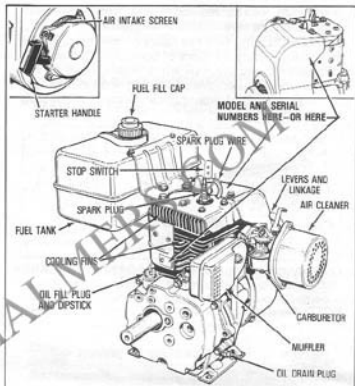

Fig. 1

- Re-install Filter per "Service Air Cleaner" instructions on page 27.

- 5** **FILL FUEL TANK** with gasoline as specified in the preceding "Oil & Fuel Recommendations," item 2 (page 26).

**NEVER MIX OIL WITH GASOLINE**

**NEVER FILL FUEL TANK INDOORS. NEVER FILL FUEL TANK WHEN ENGINE IS RUNNING OR WHILE ENGINE IS HOT.**

**NEVER FILL FUEL TANK COMPLETELY. FILL TANK TO WITHIN 1/4 TO 1/2 INCH OF TOP OF TANK TO PROVIDE SPACE FOR FUEL EXPANSION. WIPE ANY FUEL SPILLAGE FROM ENGINE AND EQUIPMENT BEFORE STARTING ENGINE.**

**Check the following** before attempting to start your engine.

- BE SURE EQUIPMENT IS IN NEUTRAL GEAR WITH CLUTCHES, BELTS, CHAINS, ETC. DISENGAGED. (FOLLOW EQUIPMENT MANUFACTURER'S INSTRUCTIONS.) THIS SHOULD PLACE ANY SAFETY SWITCHES IN SAFE STARTING POSITION.**
- Be sure Spark Plug Wire is attached to Spark Plug (see Figure 1).
- Be sure Fuel Fill Cap air vent is open.

## STARTING INSTRUCTIONS

**⚠** NEVER RUN ENGINE INDOORS OR IN ENCLOSED POORLY VENTILATED AREAS. ENGINE exhaust contains carbon monoxide, an odorless and deadly gas.

**⚠** KEEP HANDS, FEET, HAIR AND LOOSE CLOTHING AWAY FROM ANY MOVING PARTS ON ENGINE AND EQUIPMENT.

**⚠** WARNING — TEMPERATURES OF MUFFLER AND NEARBY AREAS MAY EXCEED 150°F (65°C) AVOID THESE AREAS.

① **COLD ENGINE START** (Engine has not been run recently.)

A. Move Choke Lever on engine (see Figure 2) or remote control on equipment to **Full Choke Position**.

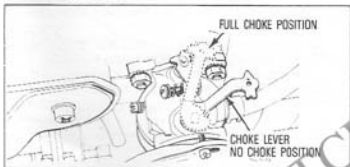

Fig. 2



Fig. 3

### 1. REWIND STARTER

A. Grasp Starter Handle (see picture) and pull rope out, slowly, until it pulls harder due to engine compression. Let rope rewind slowly.

B. Pull rope with a rapid continuous full-arm stroke. Let rope rewind slowly. Don't let Starter Handle snap back against starter.

C. Repeat preceding instructions A and B until engine fires and when engine starts, move Choke Lever on engine or remote control on

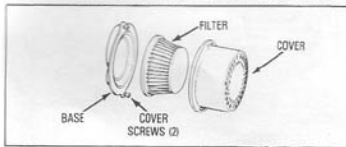

Fig. 4

equipment to 1/2 choke and then to **No Choke Position**.

If engine falters, move Choke Lever to 1/2 choke until engine runs smoothly and then to **No Choke Position**.

**NOTE:** If engine fires, but fails to start, move Choke Lever to **No Choke Position** and repeat preceding instructions A and B until engine starts.

If engine again fires, but fails to start, repeat preceding instructions A, B and C until engine starts.

**NEVER RUN ENGINE WITHOUT COMPLETE AIR CLEANER INSTALLED ON ENGINE.**

## MAINTENANCE

**⚠** WARNING — TEMPERATURE OF MUFFLER AND NEARBY AREAS MAY EXCEED 150°F (65°C) AVOID THESE AREAS.

① **CHECK OIL LEVEL REGULARLY.**

**POSITION EQUIPMENT SO ENGINE IS LEVEL.** Check level every five (5) operating hours or each time equipment is used. Always clean area around Oil Fill Plug (see Figure 1) before removing plug, to avoid contaminating oil with dirt, grass clippings, etc. Add oil as necessary. **Do not run engine unless proper oil level is maintained. Level must be between "Full" and "Add" mark on dipstick.** See instructions 2 and 3 in preceding "Pre-start Instructions" (page 26).

② **CHANGE OIL** — after first two (2) hours of operation and every twenty-five (25) hours thereafter, or more often if operated in extremely dusty or dirty areas.

**DRAIN OIL** — Position equipment so that Oil Drain Plug (see Figure 1) is lowest point on engine. Remove Oil Drain Plug and Oil Fill Plug (while engine is still warm) and allow oil to drain completely.

Replace Oil Drain Plug and tighten securely. Refill oil sump with new oil of proper viscosity and service classification per preceding "Oil & Fuel Recommendations" (page 26). Replace Oil Fill Plug and tighten securely. See Instructions in preceding "Pre-Start Instructions."

③ **SERVICE AIR CLEANER**

Your engine may be equipped with a Dry Type Paper Filter or a Foam Type Filter. Proceed with the following applicable Instruction A or B depending on type of filter:

A. **DRY TYPE PAPER FILTER** (see Figure 4)

Replace Filter once a year or more often if used in extremely dusty or dirty conditions.

**DO NOT ATTEMPT TO CLEAN OR OIL FILTER** Replacement Filters are available at any Authorized Tecumseh Service Outlet.

To install new Filter, proceed as follows:

1. Loosen two Cover Screws. (These need not

# Tecumseh

be removed completely.)

2. Turn Cover counterclockwise and remove it and Filter from Base. Discard Filter.
3. Clean inside of Base and Cover thoroughly.
4. Insert new Filter into Cover and reassemble Cover to Base as it was before removal. Tighten Cover Screws securely.

## 4 SPARK PLUG (see Figure 1)

Clean and reset gap periodically. Clean area around Spark Plug base, prior to removal, to prevent dirt from entering engine. Replace Spark Plug if electrodes are pitted or burned or if porcelain is cracked. Clean Spark Plug by carefully scraping electrodes (do not wire brush or sand blast). Be sure entire Spark Plug is clean and free of foreign material. Check electrodes gap with wire feeler gauge and reset gap to .030 if necessary. If replacing Spark Plug, use Champion J-8 or J-17LM or equivalent (see note below) and tighten to 15 foot pounds or if lacking a torque wrench tighten firmly.

**NOTE:** If your engine is equipped with a Champion RJ-17LM Resistor Spark Plug, it is in compliance with the radio noise limitations order (radio frequency interference) issued by the Ministry of Communications of the Canadian Telecommunications Regulations Branch.

To remain in compliance a Champion RJ-17LM Resistor Spark Plug *must* be used for any replacement.

- ## 5 CLEAN COOLING SYSTEM
- frequently, by removing any build-up of grass, dirt or other debris from the cylinder and cylinder head Cooling Fins, Air Intake Screen and Carburetor Governor Levers and Linkage. This will help insure adequate cooling and correct engine speed and will reduce the possibility of overheating and mechanical damage.

## ADJUSTMENTS

Do not make unnecessary adjustments. Factory settings are satisfactory for most applications and conditions. If adjustments are needed, proceed as follows:

### 1 CARBURETOR ADJUSTMENTS

High Speed Adjust Needle is pre-set at the factory. H50-60: 1-1/4 turns open

Re-adjustment should not be necessary.

- A. Close Idle Adjust Needle by turning clockwise. Close finger tight only. Forcing may cause damage.
- B. Open Idle Adjust Needle by turning counterclockwise. H50-60: 3/4 turn open.
- C. Start engine. Follow preceding starting instructions. Run engine a few minutes to warm it up.

- D. With engine running at Idle speed, adjust Idle Adjust Needle 1/8 turn at a time, clockwise and counterclockwise, until engine runs smoothly.

Allow several seconds between each adjustment for engine to adapt to new setting.

## STORAGE

**NEVER STORE ENGINE WITH FUEL IN TANK INDOORS OR IN ENCLOSED, POORLY VENTILATED ENCLOSURES, WHERE FUEL FUMES MAY REACH AN OPEN FLAME, SPARK OR PILOT LIGHT AS ON A FURNACE, WATER HEATER, CLOTHES DRYER, ETC.**

If engine is to be unused for 30 days or more, prepare as follows:

- 1 Remove all gasoline from Carburetor and Fuel Tank to prevent gum deposits from forming on these parts and causing possible malfunction of engine.

### ⚠ DRAIN FUEL INTO APPROVED CONTAINER OUTDOORS, AWAY FROM OPEN FLAME.

- A. Run engine until Fuel Tank is empty and engine stops due to lack of fuel.
- B. Disconnect Fuel Line at Carburetor or Fuel Tank. Be very careful not to damage Fuel Line, Fittings or Fuel tank. Drain any remaining fuel from System.

**NOTE:** If gasohol has been used, complete preceding instructions "A" and "B" and then put a small amount of unleaded (or leaded regular) gasoline into fuel tank and repeat preceding instructions "A" and "B."

- 2 If oil has not been changed recently, this may be a good time to do it. See "Change Oil" instructions in "Maintenance" section.
- 3 Remove Spark Plug and pour one (1) ounce (0.029 Liter) of engine oil into a spark plug hole. Crank engine over, slowly, several times.

### AVOID SPRAY FROM SPARK PLUG HOLE WHEN CRANKING ENGINE OVER SLOWLY.

Replace Spark Plug.

- 4 Clean engine by removing any clippings, dirt, or chaff from exterior of engine.



Fig. 5

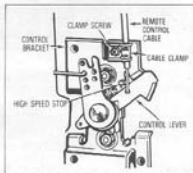

Fig. 5