

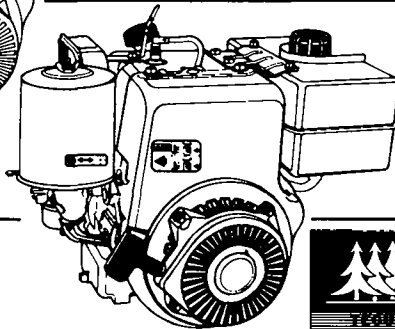

OPERATOR'S MANUAL

and MAINTENANCE INSTRUCTIONS for
TECUMSEH

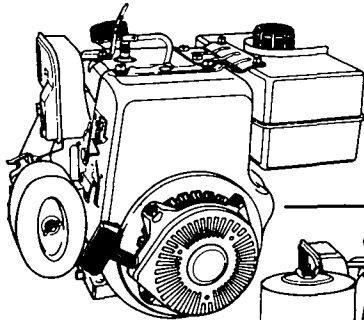

MODEL **HM80** **HM90**
 HM100 **HMM80**



HORIZONTAL CRANKSHAFT
AIR COOLED • FOUR-CYCLE ENGINE



THIS SYMBOL POINTS OUT IMPORTANT SAFETY INSTRUCTIONS WHICH IF NOT FOLLOWED COULD ENDANGER THE PERSONAL SAFETY AND/OR PROPERTY OF YOURSELF AND OTHERS. READ AND FOLLOW ALL INSTRUCTIONS IN THIS MANUAL AND ANY PROVIDED WITH THE EQUIPMENT ON WHICH THIS ENGINE IS USED BEFORE ATTEMPTING TO OPERATE YOUR TECUMSEH ENGINE.



THESE SYMBOLS MAY APPEAR ON THE ENGINE:



FAST



SLOW



STOP



OFF



CHOKE



FULL



California Proposition 65 **WARNING:** The engine exhaust from this product contains chemicals known to the State of California to cause cancer, birth defects or other reproductive harm.

3-1-99 **181-630-14**

ENGINES WHICH ARE CERTIFIED TO COMPLY WITH CALIFORNIA AND U.S. EPA EMISSION REGULATIONS FOR ULGE ENGINES, are certified to operate on regular unleaded gasoline, include the following emission control system(s): EM, TWC (if so equipped); Do not include any user adjustable features - therefore no other adjustments are needed.

OIL & FUEL RECOMMENDATIONS

TO OPERATE ENGINE, YOU WILL NEED THE FOLLOWING:

① A CLEAN, HIGH QUALITY DETERGENT OIL.

-Be sure original container is marked:

A.P.I. service "SF"- "SJ".

FOR SUMMER (ABOVE 32°F; 0°C) USE SAE 30 OIL.

Tecumseh specially formulated oil is available at any Authorized Tecumseh Service Outlet. Order as part number 730225. Using multigrade oil will increase oil consumption.

FOR WINTER (BELOW 32°F; 0°C) USE SAE 5W30 OIL.

Tecumseh specially formulated oil is available at any Authorized Tecumseh Service Outlet. Order as part number 730226.

(SAE 10W is an acceptable substitute.)

(BELOW 0°F ONLY): SAE 0W30 OIL is an acceptable substitute.

DO NOT USE SAE 10W40 OIL.

OIL SUMP CAPACITY:

Models HM70-80-100, HMXL70: 26 ounces
(1-5/8 U.S. pints)

Model HMM80: 34 ounces
(2-1/8 U.S. pints)

② A FRESH, CLEAN, UNLEADED REGULAR, UNLEADED PREMIUM, OR REFORMULATED AUTOMOTIVE GASOLINE ONLY. DO NOT USE LEADED GASOLINE.

NOTE: DO NOT USE GASOLINE CONTAINING METHANOL (WOOD ALCOHOL). Gasoline containing up to 10% ethanol or grain alcohol ("Gasohol") may be used but requires special care when engine is used for extended periods. See "STORAGE" instructions on Page 5.

NOTE: Use clean oil and fuel and store in approved, clean, covered containers. Use clean fill funnels.

Never use "stale" gasoline left over from last season or stored for long periods.

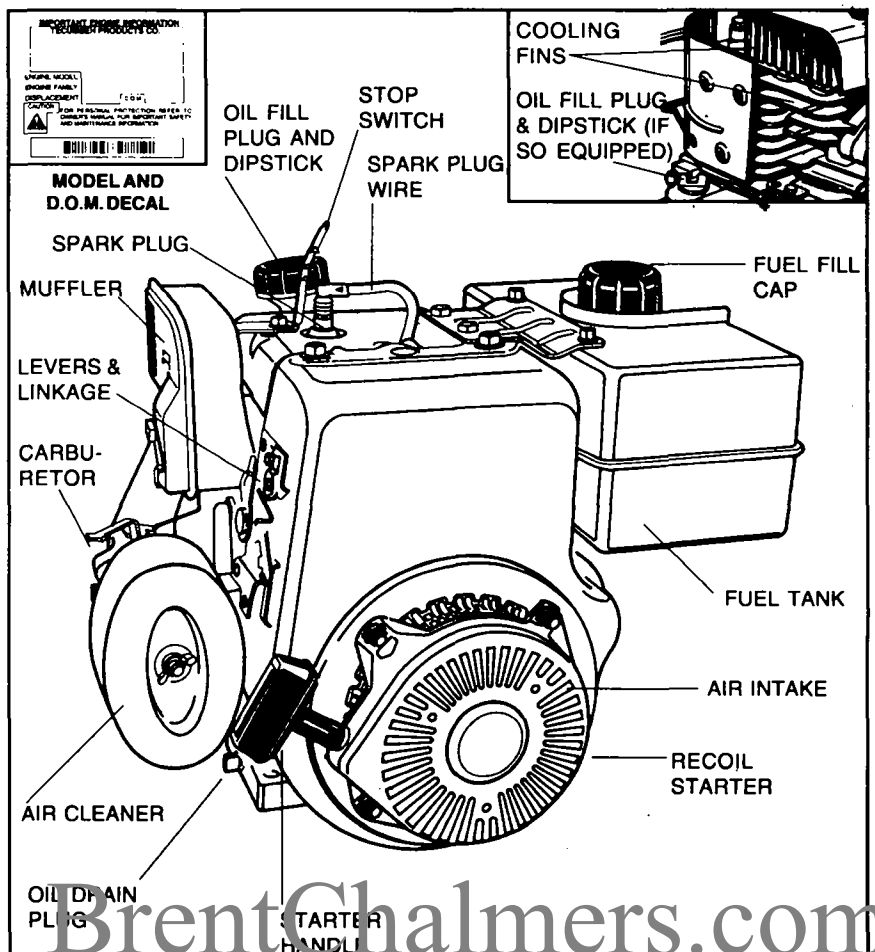

BrentChalmers.com

WARRANTY AND REPAIR



For engine adjustment, repairs, or warranty service not covered in this manual, contact your nearest AUTHORIZED TECUMSEH SERVICE OUTLET. It is listed in your telephone book yellow pages under "Engines, Gasoline."

If you have a general understanding of internal combustion engine and wish to repair and service your engine yourself, a "MECHANICS HANDBOOK" which covers repairs and adjustments not covered in this OPERATOR'S MANUAL is available from your AUTHORIZED TECUMSEH SERVICE OUTLET. Order as Part No. 692509.

Tecumseh manufactures and is responsible only for the engine used on this power equipment. If repair or service is needed for unit, other than engine, contact service source as recommended by equipment manufacturer.

Warranty requirements for engines sold outside of the USA may vary from country to country. For warranty details for your specific country, contact your national Tecumseh Service Distributor. If help is needed in locating your national service distributor, you may contact Tecumseh c/o International Service Coordinator, Engine & Transmission Group Service Division, 900 North Street, Grafton, Wisconsin USA 53024-1499. Telephone in USA is 414-377-2700.



LIMITED WARRANTY FOR NEW TECUMSEH ENGINES AND ELECTRONIC IGNITION MODULES

For the time period shown below from the date of purchase, Tecumseh Products Company will, at its option as the exclusive remedy, either repair or replace for the original purchaser, free of charge, any part of any new Tecumseh engine which is found, upon examination by any Tecumseh Authorized Service Outlet or by Tecumseh's factory in Grafton, Wisconsin, to be **DEFECTIVE IN MATERIAL AND/OR WORKMANSHIP**, except as provided below. This Limited Warranty **DOES NOT COVER** (i) any Tecumseh engine or part(s) thereof used to power any vehicle in competitive racing and/or used on any commercial or rental track, or (ii) defects or damage caused by alterations or modifications of new Tecumseh engines or parts or by normal wear, accidents, improper maintenance, improper use or abuse of the product, or failure to follow the instructions contained in an Instruction Manual for the operation of the new Tecumseh engine or part. The cost of normal maintenance or replacement of service items which are not defective shall be paid for by the original purchaser. At the time warranty service is requested, evidence must be presented of the date of purchase by the original purchaser. Any charge for making service calls and/or for transporting any engine or part(s) thereof to and from the place where the inspection and/or warranty work is performed is payable solely by the purchaser. The purchaser is responsible for any damage or loss incurred in connection with the transportation of any engine or part(s) thereof submitted for inspection and/or warranty work. **WARRANTY SERVICE CAN ONLY BE PERFORMED BY A TECUMSEH AUTHORIZED SERVICE OUTLET OR BY TECUMSEH AT ITS FACTORY IN GRAFTON, WISCONSIN.** Warranty service can be arranged by contacting either a Tecumseh Authorized Service Outlet (any Tecumseh Registered Service Dealer, Tecumseh Master Service Dealer, Tecumseh Authorized Service Distributor, or Tecumseh Central Warehouse Distributor) or by contacting Tecumseh c/o Service Manager, Engine and Transmission Group Service Division, 900 North Street, Grafton, Wisconsin 53024-1499.

ENGINE WARRANTY PERIOD				
Warranty Category†	"CONSUMER USE" +		"COMMERCIAL USE" ++	
	Within U.S.A. and Canada	Outside U.S.A. and Canada	Within USA and Canada	Outside USA and Canada
(A)	90 day	90 day	No Warranty	No Warranty
(B)	1 Year	1 Year	1 Year	1 Year
(C)	2 Years	1 Year	1 Year	1 Year
(D)	2 Years	2 Years**	1 Year	1 Year
(E)	2 Years	2 Years	1 Year	1 Year
(H)	2 'n 10*	2 'n 10*	1 Year	1 Year
(K)	2 'n 10*	2 'n 10*	2 'n 10*	1 Year

* 2 years on engine, 10 years on electronic ignition.
 ** 1 year for Australia/New Zealand for rotary mower engines.
 + For purposes of this warranty policy, "consumer use" shall mean consumer's personal, residential, household use by the original retail purchaser.
 ++ For purposes of this warranty policy, "commercial use" shall mean all other uses, including use for commercial, income producing, or rental purposes.
 † The engine warranty category of your engine can be determined by review of the engine model number on the "Important Engine Information" decal. One letter in the engine model number will be surrounded by parens (A), (B), (C), (D), (E), (H) or (K) and that letter is your engine warranty category designation. IN CALIFORNIA ONLY, THIS EXPRESS WARRANTY IS SUPPLEMENTED BY THE TECUMSEH CALIFORNIA EMISSION CONTROL WARRANTY STATEMENT.

THIS EXPRESS WARRANTY IS IN LIEU OF ALL OTHER EXPRESS WARRANTIES. Neither Tecumseh nor any of its affiliates makes any warranties, representations, or promises, written or oral, as to the quality of the engine or any of its parts, other than as set forth herein. ANY IMPLIED WARRANTY OF MARKETABILITY OR FITNESS FOR A PARTICULAR PURPOSE, TO THE EXTENT THAT EITHER MAY APPLY TO ANY TECUMSEH ENGINE OR PART(S) THEREOF, SHALL BE LIMITED IN DURATION TO THE PERIODS OF THE EXPRESS WARRANTIES SHOWN IN THE WARRANTY PERIOD CHART ABOVE AND TO THE EXTENT PERMITTED BY LAW AND ALL IMPLIED WARRANTIES ARE EXCLUDED. IN NO EVENT WILL TECUMSEH BE LIABLE FOR ANY INCIDENTAL, CONSEQUENTIAL OR SPECIAL DAMAGES AND/OR EXPENSES. Some states do not allow limitations on how long an implied warranty lasts or the exclusion or limitation of incidental or consequential damages, so the above limitation(s) or exclusion(s) may not apply to you. This Limited Warranty gives you specific legal rights and you may also have other legal rights which vary from state-to-state.

6-1-95

FILL IN: EXAMPLE: HM80 155000P (B) 5001A
 ENGINE SPEC. WARRANTY SERIAL ENGINE SPEC. WARRANTY SERIAL
 MODEL NUMBER PERIOD NUMBER MODEL NUMBER PERIOD NUMBER



BEFORE STARTING

① READ ALL INSTRUCTIONS PROVIDED WITH THE EQUIPMENT ON WHICH THIS ENGINE IS USED.

② FILL OIL SUMP OR CHECK OIL LEVEL:

IMPORTANT: To avoid engine damage never run engine unless:

- Oil level is between "FULL" and "ADD" marks on dipstick.
- Oil fill plug is tightened securely into oil fill tube or hole.

CHECK OIL LEVEL OFTEN DURING ENGINE BREAK-IN.

- POSITION EQUIPMENT SO ENGINE IS LEVEL.
- Clean area around oil fill plug (see Figure 1).
- Remove oil fill plug and dipstick.
- Wipe dipstick clean, insert it into oil fill hole and tighten securely, remove dipstick. If oil is not up to "FULL" mark on dipstick, add recommended oil. POUR SLOWLY. Wipe dipstick clean each time oil level is checked.

IMPORTANT: DO NOT FILL ABOVE "FULL" MARK ON DIPSTICK.

- Install oil fill plug and dipstick, tighten securely.

See "MAINTENANCE" section for further oil instructions.

③ FILL FUEL TANK:

- Clean area around fuel fill cap, remove cap.
- Add "UNLEADED" regular gasoline, slowly, to fuel tank. Use a funnel to help avoid spillage.

IMPORTANT: NEVER MIX OIL WITH GASOLINE

- Install fuel fill cap and wipe up any spilled gasoline.

NEVER FILL FUEL TANK INDOORS. NEVER FILL FUEL TANK WHEN ENGINE IS RUNNING OR HOT. DO NOT SMOKE WHEN FILLING FUEL TANK.

NEVER FILL FUEL TANK COMPLETELY. FILL TANK TO 1/2" BELOW BOTTOM OF FILLER NECK TO PROVIDE SPACE FOR FUEL EXPANSION. WIPE ANY FUEL SPILLAGE FROM ENGINE AND EQUIPMENT BEFORE STARTING ENGINE.

ANY LIQUEFIED PETROLEUM (LPG) OR NATURAL GAS FUEL SYSTEM MUST BE LEAKPROOF AND MEET ALL APPLICABLE CODES AND REGULATIONS.

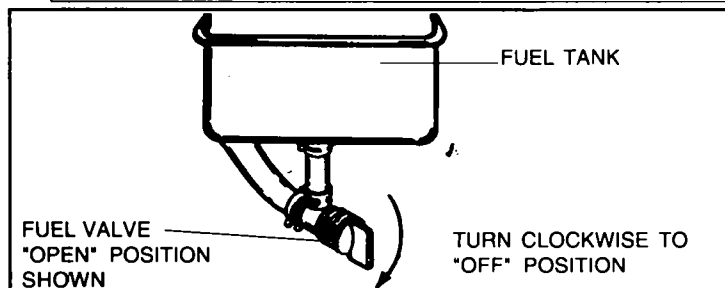

Figure 2

④ CHECK THE FOLLOWING:

A. BE SURE EQUIPMENT IS IN NEUTRAL GEAR WITH CLUTCHES, BELTS, CHAINS AND SAFETY SWITCHES DISENGAGED. (FOLLOW EQUIPMENT MANUFACTURER'S INSTRUCTIONS.) THIS SHOULD PLACE ANY SAFETY SWITCHES IN SAFE STARTING POSITION.

- Be sure spark plug wire is attached to spark plug (see Figure 1).
- Be sure stop switch (if so equipped see Figure 1) is not contacting spark plug.
- Be sure any ignition switch and/or control lever on engine or equipment is in "ON", "RUN" or "START" position.
- Be sure fuel valve (if so equipped see Figure 2) is open.

⑤ If your engine is equipped with a CLIMATE GUARD air cleaner, make sure scoop is positioned correctly:

- **WINTER** (Below 32°F; 0°C): Scoop should be pointed directly at muffler.
- **SUMMER** (Above 32°F; 0°C): Scoop should be pointed towards blower housing (approximately 45° clockwise from "winter position").

IMPORTANT: In order for engine to operate smoothly and efficiently, it is important for scoop to be in proper position for season.

If your engine is not equipped with a CLIMATE GUARD air cleaner, and you would like to operate your engine in temperatures below 32°F (0°C), a CLIMATE GUARD Conversion Kit is available at any Authorized Tecumseh Service Outlet. Order as kit number 730630.

STARTING

NEVER RUN ENGINE INDOORS OR IN ENCLOSED, POORLY VENTILATED AREAS. ENGINE EXHAUST CONTAINS CARBON MONOXIDE, AN ODORLESS AND DEADLY GAS.

KEEP HANDS, FEET, HAIR AND LOOSE CLOTHING AWAY FROM ANY MOVING PARTS ON ENGINE AND EQUIPMENT.

WARNING: TEMPERATURE OF MUFFLER AND NEARBY AREAS MAY EXCEED 150°F (65°C). AVOID THESE AREAS.

① RECOIL STARTER:

- Move choke lever (see Figure 3 or 4) to "FULL CHOKE POSITION".
NOTE: IF RESTARTING A WARM ENGINE AFTER A SHORT SHUTDOWN, MOVE CHOKE LEVER TO "NO CHOKE POSITION".

- Move equipment control (see manufacturer's instructions) or engine control to "START".

- Grasp starter handle (see Figure 1) and pull rope out, slowly, until it pulls harder. Let rope rewind slowly. Then pull rope with a rapid full arm stroke. Let rope return to starter slowly.

- When engine starts, move choke lever to "1/2 CHOKE" until engine runs smoothly and then to "NO CHOKE POSITION". If engine falters, move choke lever to "1/2 CHOKE" until engine runs smoothly and then to "NO CHOKE POSITION".

NOTE: If engine fails to start after three (3) pulls, move choke lever to "NO CHOKE POSITION" and pull starter rope again.

NOTE: If engine fires, but does not continue to run, move choke lever to "FULL CHOKE" and repeat instructions B, C and D until engine starts.

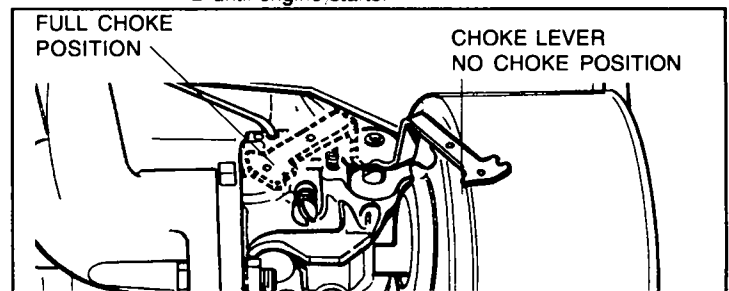

Figure 3

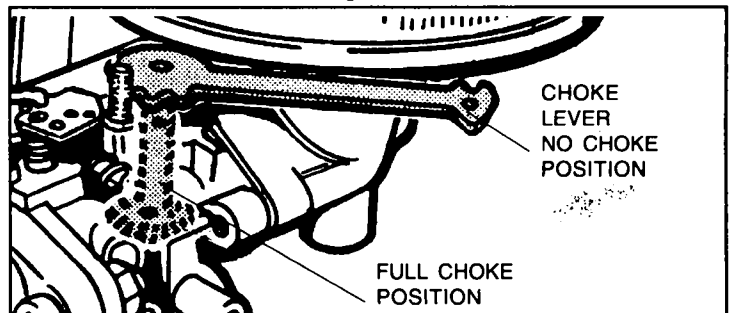

Figure 4

ADJUSTMENTS (Continued)

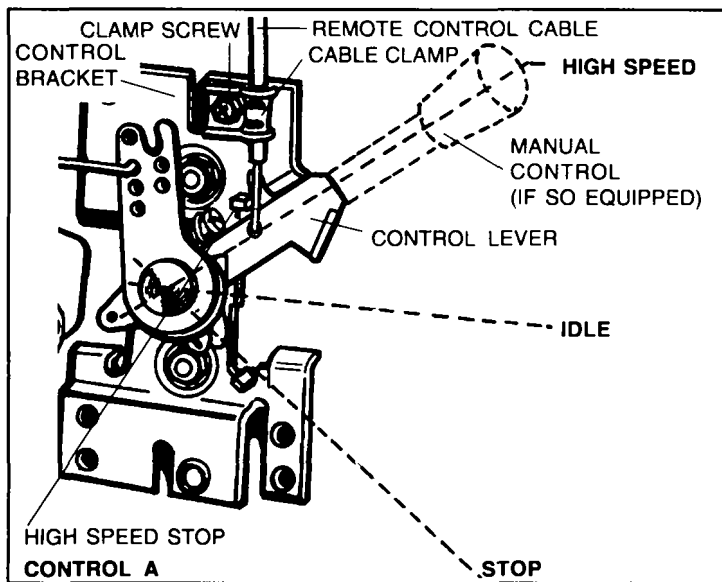

Figure 8

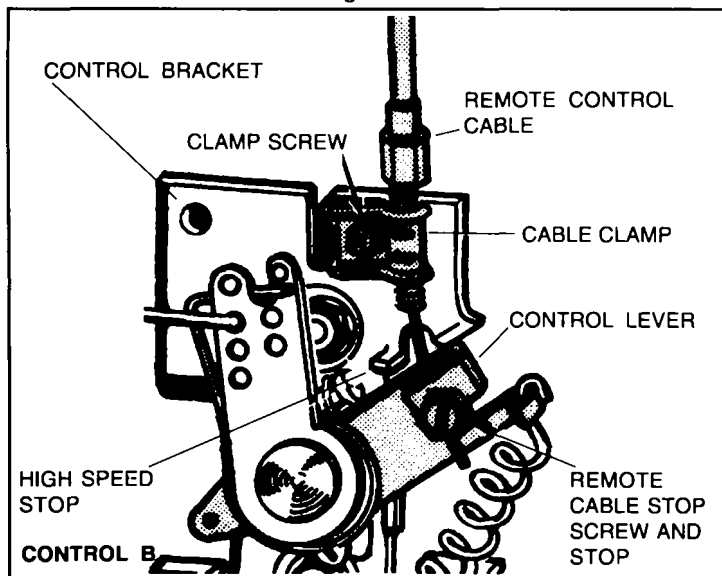

Figure 9

② CARBURETOR:

If you think your carburetor needs adjusting, see your nearest AUTHORIZED TECUMSEH SERVICE OUTLET. Engine performance should not be affected at altitudes up to 7,000 feet. For operation at higher elevations, contact your AUTHORIZED TECUMSEH SERVICE OUTLET.

③ ENGINE SPEED:

NEVER TAMPER WITH ENGINE GOVERNOR WHICH IS FACTORY SET FOR PROPER ENGINE SPEED. OVERSPEEDING ENGINE ABOVE FACTORY HIGH SPEED SETTING CAN BE DANGEROUS. CHANGING OF ENGINE GOVERNED SPEED WILL VOID ENGINE WARRANTY.

For engine adjustments and/or repairs not covered in this "OPERATOR'S MANUAL" see "WARRANTY & REPAIR" on Page 6.

STORAGE

NEVER STORE ENGINE WITH FUEL IN TANK INDOORS OR IN ENCLOSED, POORLY VENTILATED AREAS, WHERE FUEL FUMES MAY REACH AN OPEN FLAME, SPARK OR PILOT LIGHT AS ON A FURNACE, WATER HEATER, CLOTHES DRYER OR OTHER GAS APPLIANCE.

IF ENGINE IS TO BE UNUSED FOR 30 DAYS OR MORE, PREPARE AS FOLLOWS:

① DRAIN FUEL SYSTEM:

A. Remove all gasoline from carburetor and fuel tank to prevent gum deposits from forming on these parts and causing possible malfunction of engine.

DRAIN FUEL INTO APPROVED CONTAINER OUTDOORS, AWAY FROM OPEN FLAME. BE SURE ENGINE IS COOL. DO NOT SMOKE.

B. Run engine until fuel tank is empty and engine stops due to lack of fuel.

NOTE: If "Gasohol" has been used, complete above instructions and then put 1/2 pint of "Unleaded" gasoline into fuel tank and repeat above instructions.

NOTE: Tecumseh SMART START™ gasoline preservative and stabilizer is an acceptable alternative in minimizing the formation of fuel gum deposits during storage. Add stabilizer to gasoline in fuel tank or storage container. Always follow mix ratio found on stabilizer container. Run engine at least 10 minutes after adding stabilizer to allow it to reach carburetor.

② DRAIN CARBURETOR (if so equipped):

Drain carburetor by pressing upward on bowl drain (see Figure 10), which is located below carburetor (see Figure 1).

DRAIN FUEL INTO APPROVED CONTAINER OUTDOORS, AWAY FROM OPEN FLAME. BE SURE ENGINE IS COOL. DO NOT SMOKE.

NOTE: Do not drain carburetor if using fuel stabilizer.

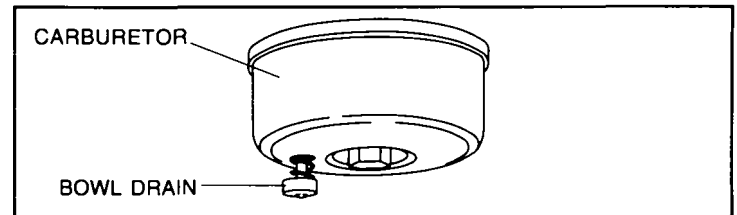

Figure 10

③ CHANGE OIL:

Change oil if it has not been changed in the last three (3) months. See "CHANGE OIL" instructions in "MAINTENANCE" section.

④ OIL CYLINDER BORE:

- Remove spark plug. Squirt one (1) oz. (30 ml) of clean engine oil into spark plug hole.
- Cover spark plug hole with a rag.
- Crank engine over, slowly, several times.

AVOID SPRAY FROM SPARK PLUG HOLE WHEN CRANKING ENGINE OVER SLOWLY.

D. Install spark plug. Do not connect spark plug wire.

⑤ CLEAN ENGINE:

Remove any clippings, dirt, or chaff from exterior of engine.

⑥ BATTERY (if so equipped):

See equipment manufacturer's instructions for proper storage of battery.

STARTING (Continued)

② ELECTRIC STARTER:

- A. Move choke lever (see Figure 3 or 4) to "FULL CHOKE POSITION".
NOTE: IF RESTARTING A WARM ENGINE AFTER A SHORT SHUTDOWN, MOVE CHOKE LEVER TO "NO CHOKE POSITION".

B. Move equipment control (see manufacturer's instructions) or engine control to "START".

C. Push starter button or turn ignition switch key (see equipment manufacturer's instructions) to crank engine.

D. Crank engine until it fires. When it starts, release starter button or ignition switch key and move choke lever to "1/2 CHOKE" until engine runs smoothly and then to "NO CHOKE POSITION".

If engine falters, move choke lever to "1/2 CHOKE" until engine runs smoothly and then to "NO CHOKE POSITION".

NOTE: If engine fires, but does not continue to run, move choke lever to "NO CHOKE POSITION" and crank engine until it starts.

NOTE: If engine again fires, but does not continue to run, move choke lever to "FULL CHOKE" and repeat instructions B, C and D until engine starts.

STOPPING

- ① Move equipment control or any ignition stop switch on engine to "STOP" or "OFF" (see equipment manufacturer's instructions).

② Push stop switch (if so equipped see Figure 1) located next to spark plug on engine against spark plug and hold it in this position until engine is completely stopped.

③ AFTER ENGINE IS STOPPED:

A. Close fuel valve (if so equipped).

⚠ B. DISCONNECT SPARK PLUG WIRE FROM SPARK PLUG AND KEEP IT AWAY FROM SPARK PLUG.

⚠ C. TURN IGNITION SWITCH KEY (IF SO EQUIPPED) TO "OFF" POSITION AND REMOVE KEY FROM SWITCH, THIS WILL REDUCE THE POSSIBILITY OF UNAUTHORIZED STARTING OF ENGINE WHILE EQUIPMENT IS NOT IN USE.

⚠ NEVER STORE ENGINE WITH FUEL IN TANK INDOORS OR IN ENCLOSED, POORLY VENTILATED AREAS, WHERE FUEL FUMES MAY REACH AN OPEN FLAME, SPARK OR PILOT LIGHT AS ON A FURNACE, WATER HEATER, CLOTHES DRYER OR OTHER GAS APPLIANCE.

MAINTENANCE

⚠ WARNING: TEMPERATURE OF MUFFLER AND NEARBY AREAS MAY EXCEED 150°F (65°C). AVOID THESE AREAS.

① OIL LEVEL:

Check oil level every five (5) operating hours and before each use. See "FILL OIL SUMP OR CHECK OIL LEVEL" on Page 2.

② CHANGE OIL (see Figure 1):

Change oil after first two (2) operating hours and every 25 operating hours thereafter, more often if operated in extremely dusty or dirty conditions.

Change oil while engine is still warm from recent running.

⚠ A. DISCONNECT SPARK PLUG WIRE FROM SPARK PLUG AND KEEP IT AWAY FROM SPARK PLUG.

B. Clean area around oil drain plug (see Figure 1).

C. Position equipment so engine oil drain plug is lowest point on engine.

D. Remove oil drain plug and oil fill plug to drain oil.

E. Install oil drain plug and tighten securely.

F. Fill oil sump with recommended oil. See "OIL & FUEL RECOMMENDATIONS" on Pages 1 and 2 and "FILL OIL SUMP OR CHECK OIL LEVEL" on Page 2.

G. Install oil fill plug and tighten securely.

H. Wipe up any spilled oil.

MAINTENANCE (Continued)

③ COOLING SYSTEM (see Figure 1 and Figure 5):

IMPORTANT: Frequently remove grass clippings, dirt and debris from cooling fins, air intake screen and levers and linkage. This will help ensure adequate cooling and correct engine speed.

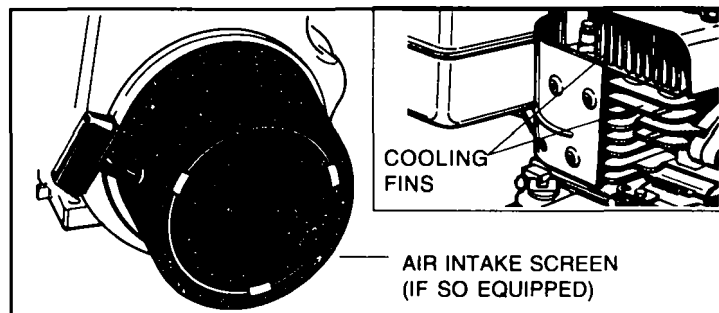

Figure 5

④ SPARK PLUG (see Figure 6):

This spark ignition system meets all requirements of the Canadian Interference-Causing Equipment Regulations. This engine complies with all current Australian and New Zealand limitations regarding electromagnetic interference. Check spark plug yearly or every 100 operating hours.

A. Clean area around spark plug.

B. Remove and inspect spark plug.

C. Replace spark plug if electrodes are pitted, burned or porcelain is cracked. For replacement use Champion RJ-17LM only.

NOTE: A resistor spark plug must be used for replacement.

D. Check electrode gap with wire feeler gauge and set gap at .030 if necessary.

E. Install spark plug, tighten securely.

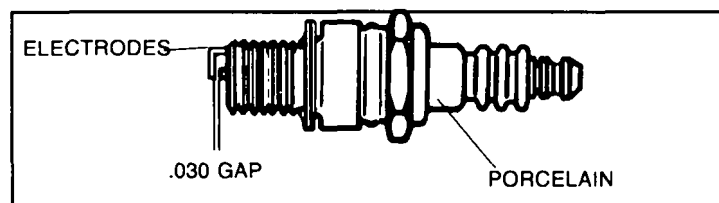

Figure 6

⑤ AIR CLEANER:

IMPORTANT: NEVER RUN ENGINE WITHOUT COMPLETE AIR CLEANER INSTALLED ON ENGINE.

A. TO SERVICE FILTER(S) (see Figure 7):

1. FOAM FILTER:

Clean and re-oil every three (3) months or every 25 operating hours. Clean and re-oil daily if used in extremely dusty conditions.

NOTE: DO NOT OIL FOAM FILTER ON AIR CLEANER "A".

a. Wash in water and detergent solution and squeeze (don't twist) until all dirt is removed.

b. Rinse thoroughly in clear water.

c. Wrap in a clean cloth and squeeze (don't twist) until completely dry.

d. Saturate with engine oil and squeeze (don't twist) to distribute oil and remove excess oil.

2. PAPER FILTER:

DO NOT ATTEMPT TO CLEAN OR OIL FILTER.

Replace once a year or every 100 operating hours, more often if used in extremely dusty conditions. Replacement filters are available at any Authorized Tecumseh Service Outlet.

EMISSION CONTROL SYSTEM WARRANTY

Emission Control System Warranty ("ECS Warranty") for 1995 and later model year California utility and lawn and garden equipment engines (for other states, 1997 and later model year engines):

- A. APPLICABILITY:** This warranty shall apply to 1995 and later model year California utility and lawn and garden equipment engines (for other states, 1997 and later model year engines). The ECS Warranty Period shall begin on the date the new engine or equipment is delivered to its original, end-use purchaser, and shall continue for 24 consecutive months thereafter.
- B. GENERAL EMISSIONS WARRANTY COVERAGE:** Tecumseh Products Co. warrants to the original, end-use purchaser of the new engine or equipment and to each subsequent purchaser that each of its utility and lawn and garden equipment engines is:
1. Designed, built and equipped so as to conform with all applicable regulations adopted by the Air Resources Board pursuant to its authority in Chapters 1 and 2, Part 5, Division 26 of the Health and Safety Code, and
 2. Free from defects in materials and workmanship which, at any time during the ECS Warranty Period, will cause a warranted emissions-related part to fail to be identical in all material respects to the part as described in the engine manufacturer's application for certification.
- C. The ECS Warranty only pertains to emissions-related parts on your engine, as follows:**
1. Any warranted, emissions-related parts which are not scheduled for replacement as required maintenance in the Owner's Manual shall be warranted for the ECS Warranty Period. If any such part fails during the ECS Warranty Period, it shall be repaired or replaced by Tecumseh Products Co. according to Subsection 4 below. Any such part repaired or replaced under the ECS Warranty shall be warranted for any remainder of the ECS Warranty Period.
 2. Any warranted, emissions-related part which is scheduled only for regular inspection as specified in the Owner's Manual shall be warranted for the ECS Warranty Period. A statement in such written instructions to the effect of "repair or replace as necessary", shall not reduce the ECS Warranty Period. Any such part repaired or replaced under the ECS Warranty shall be warranted for the remainder of the ECS Warranty Period.
 3. Any warranted, emissions-related part which is scheduled for replacement as required maintenance in the Owner's Manual, shall be warranted for the period of time prior to the first scheduled replacement point for that part. If the part fails prior to the first scheduled replacement, the part shall be repaired or replaced by Tecumseh Products Co. according to Subsection 4 below. Any such emissions-related part repaired or replaced under the ECS Warranty, shall be warranted for the remainder of the ECS Warranty Period prior to the first scheduled replacement point for such emissions-related part.
 4. Repair or replacement of any warranted, emissions-related part under this ECS Warranty shall be performed at no charge to the owner at a Tecumseh Authorized Service Outlet.
 5. The owner shall not be charged for diagnostic labor which leads to the determination that a part covered by the ECS Warranty is in fact defective, provided that such diagnostic work is performed at a Tecumseh Authorized Service Outlet.
 6. Tecumseh Products Co. shall be liable for damages to other original engine components or approved modifications proximately caused by a failure under warranty of an emission-related part covered by the ECS Warranty.
 7. Throughout the ECS Warranty Period, Tecumseh Products Co. shall maintain a supply of warranted emission-related parts sufficient to meet the expected demand for such emission-related parts.
 8. Any Tecumseh Products Co. authorized and approved emission-related replacement part may be used in the performance of any ECS Warranty maintenance or repair and will be provided without charge to the owner. Such use shall not reduce Tecumseh Products Co. ECS Warranty obligations.
 9. Unapproved add-on or modified parts may not be used to modify or repair a Tecumseh Products Co. engine. Such use voids this ECS Warranty and shall be sufficient grounds for disallowing an ECS Warranty claim. Tecumseh Products Co. shall not be liable hereunder for failures of any warranted parts of a Tecumseh Products Co. engine caused by the use of such an unapproved add-on or modified part.

EMISSION-RELATED PARTS INCLUDE THE FOLLOWING:

1. Carburetor Assembly and its Internal Components
 - a) Fuel filter
 - b) Carburetor gaskets
 - c) Intake pipe
2. Air Cleaner Assembly
 - a) Air filter element
3. Ignition System, including:
 - a) Spark plug
 - b) Ignition module
 - c) Flywheel assembly
4. Catalytic Muffler (if so equipped)
 - a) Muffler gasket (if so equipped)
 - b) Exhaust manifold (if so equipped)
5. Crankcase Breather Assembly and its Components
 - a) Breather connection tube

MAINTENANCE (Continued)

B. TO REMOVE AND INSTALL FILTER(S):

AIR CLEANER "A" (see Figure 7):

1. Remove wing nut and cover.
2. Slide foam filter (if so equipped) off paper filter.
3. Discard paper filter.
4. Clean inside of base and cover thoroughly.
5. Install new paper filter on base.
6. Slide foam filter (if so equipped) over paper filter.
7. Install cover and wing nut. Tighten wing nut securely.

AIR CLEANER "B" & "C" (see Figure 7):

1. Remove wing nut and cover.
2. Slide foam filter off paper filter.
3. Inspect filters for discoloration or dirt accumulation. If either is present, service per preceding "TO SERVICE FILTER(S)" instructions.
4. Remove paper filter (if service is necessary).
5. Clean topside of base and inside of cover thoroughly.
6. Install paper filter.
7. Slide foam filter over paper filter.
8. Install cover and wing nut. Tighten wing nut securely.

NOTE: In Air Cleaner "C" application, make sure to position scoop correctly:

- **WINTER** (Below 32°F; 0°C): Scoop should be pointed directly at muffler.
- **SUMMER** (Above 32°F; 0°C): Scoop should be pointed towards blower housing (approximately 45° clockwise from "winter position").

IMPORTANT: In order for engine to operate smoothly and efficiently, it is important for scoop to be in proper position for season.

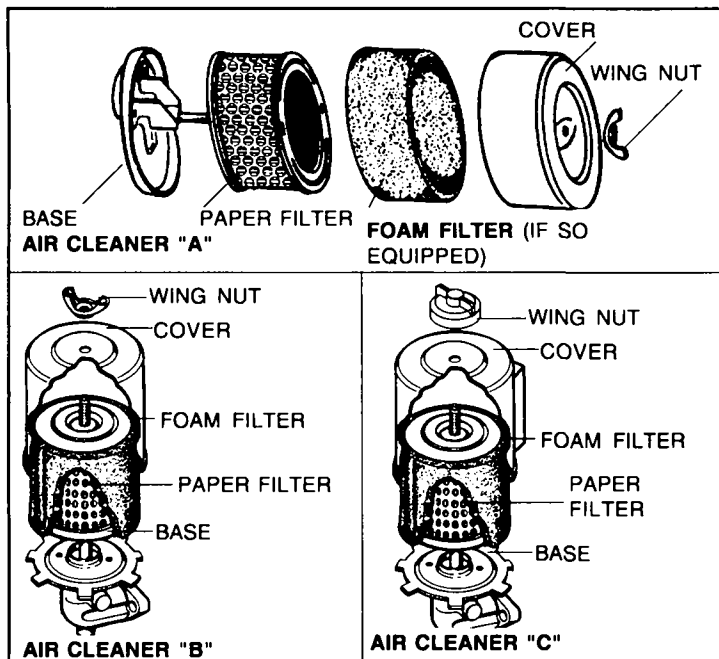

Figure 7

MAINTENANCE (Continued)

⑥ ALTERNATOR AND BATTERY (if so equipped):

A. ALTERNATOR:

For electrical problems such as inoperative starter or discharged battery see equipment manufacturer's instructions for fuse replacement, maintenance and repairs.

B. BATTERY:

1. When servicing battery, always connect cables to battery exactly as they were before removal (ground cable to battery negative [- or neg.] post). If incorrectly connected, fuse (if so equipped), will blow and alternator won't charge battery. If this happens, connect cables correctly and replace fuse.
2. Never expose engine ignition system to battery power. If battery cable or any live wire contacts ignition system ground wire, engine ignition system may be damaged.
3. If external battery charger is used, disconnect positive (+ or pos.) cable from battery to prevent possible damage.
4. See battery manufacturer's instructions for service and storage.

⑦ CHECK ENGINE AND EQUIPMENT OFTEN FOR LOOSE NUTS, BOLTS AND ATTACHMENTS AND KEEP THESE ITEMS TIGHTENED.

ADJUSTMENTS

DO NOT MAKE UNNECESSARY ADJUSTMENTS. FACTORY SETTINGS ARE SATISFACTORY FOR MOST CONDITIONS. IF ADJUSTMENTS ARE NEEDED, PROCEED AS FOLLOWS:

① REMOTE CONTROL (see Figure 8 or 9):

For satisfactory engine performance, engine and equipment control must be adjusted properly. To check engine control adjustments, proceed as follows:

Set equipment control at "FAST" or "HIGH SPEED" and keep it in this position. In this position, engine control lever should touch "HIGH SPEED STOP". If it does, the controls are adjusted correctly and no further adjustment should be necessary.

NOTE: If engine control lever does not touch "HIGH SPEED STOP", proceed to **CONTROL A** in Figure 8 or **CONTROL B** in Figure 9.

CONTROL A (see Figure 8):

- A. Loosen clamp screw so remote control cable can be moved in cable clamp (do not remove cable clamp from control bracket or disconnect remote control cable from engine control lever).
- B. Move engine control lever so it is touching "HIGH SPEED STOP" and hold it in this position.
- C. Tighten clamp screw securely so cable clamp will hold remote control cable in place when equipment control is used.

The engine controls should now be adjusted correctly.

If additional adjustments are needed, make them at the equipment control (see equipment manufacturer's instructions).

CONTROL B (see Figure 9):

- A. Hold control lever in an upward position, as close as possible to "HIGH SPEED STOP" and loosen, but do not remove remote cable stop screw.
- B. Move remote cable stop upward on remote control cable so it holds control lever against "HIGH SPEED STOP" and tighten remote cable stop screw securely.

The engine controls should now be adjusted correctly.

If additional adjustments are needed, make them at the equipment control (see equipment manufacturer's instructions).

CALIFORNIA & US EPA EMISSION CONTROL WARRANTY STATEMENT

The U. S. Environmental Protection Agency ("EPA"), the California Air Resources Board ("CARB") and Tecumseh Products Co. are pleased to explain the Federal and California Emission Control Systems Warranty on your new utility or lawn and garden equipment engine. In California, new 1995 and later utility and lawn and garden equipment engines must be designed, built and equipped to meet the State's stringent anti-smog standards. In other states, new 1997 and later model year engines must be designed, built and equipped, at the time of sale, to meet the U.S. EPA regulations for small non-road engines. Tecumseh Products Co. will warrant the emission control system on your utility or lawn and garden equipment engine for the periods of time listed below, provided there has been no abuse, neglect, unapproved modification, or improper maintenance of your utility or lawn and garden equipment engine.

Your emission control system may include parts such as the carburetor, ignition system and exhaust system. Also included may be the compression release system and other emission-related assemblies.

Where a warrantable condition exists, Tecumseh Products Co. will repair your utility or lawn and garden equipment engine at no cost to you for diagnosis, parts and labor.

MANUFACTURER'S EMISSION CONTROL SYSTEM WARRANTY COVERAGE

Emission control systems on 1995 and later model year California utility and lawn and garden equipment engines are warranted for two years as hereinafter noted. In other states, 1997 and later model year engines are also warranted for two years. If, during such warranty period, any emission-related part on your engine is defective in materials or workmanship, the part will be repaired or replaced by Tecumseh Products Co.

OWNER'S WARRANTY RESPONSIBILITIES

As the utility or lawn and garden equipment engine owner, you are responsible for the performance of the required maintenance listed in your Owner's Manual, but Tecumseh Products Co. will not deny warranty solely due to the lack of receipts or for your failure to provide written evidence of the performance of all scheduled maintenance.

As the utility or lawn and garden equipment engine owner, you should, however, be aware that Tecumseh Products Co. may deny you warranty coverage if your utility or lawn and garden equipment or a part thereof has failed due to abuse, neglect, improper maintenance or unapproved modifications.

You are responsible for presenting your utility or lawn and garden equipment engine to a Tecumseh Authorized Service Outlet (any Tecumseh Registered Service Dealer, Tecumseh Authorized Service Distributor or Tecumseh Central Warehouse Distributor) as soon as a problem exists. The warranty repairs should be completed in a reasonable amount of time, not to exceed 30 days.

Warranty service can be arranged by contacting either a Tecumseh Authorized Service Outlet or by contacting Tecumseh Products Co., c/o Service Manager, Engine and Transmission Group Service Division, 900 North Street, Grafton, WI 53024-1499. Telephone 1-414-377-2700, or see your local telephone yellow pages under "Engines, Gasoline" for the name, address and telephone number of a Tecumseh Authorized Service Outlet near you.

IMPORTANT NOTE

This warranty statement explains your rights and obligations under the Emission Control System Warranty ("ECS Warranty") which is provided to you by Tecumseh Products Co. pursuant to California law. Tecumseh Products Co. also provides to original purchasers of new Tecumseh Products Co. engines. The Tecumseh Products Co. Limited Warranties for New Tecumseh Engine and Electronic Ignition Modules ("Tecumseh Products Co. Warranty") which is enclosed with all new Tecumseh Products Co. engines on a separate sheet. The ECS Warranty applies only to the emission control system of your new engine. To the extent that there is any conflict in terms between the ECS Warranty and the Tecumseh Products Co. Warranty, the ECS Warranty shall apply except in any circumstances in which the Tecumseh Products Co. Warranty may provide a longer warranty period. Both the ECS Warranty and the Tecumseh Products Co. Warranty describe important rights and obligations with respect to your new engine.

Warranty service can only be performed by a Tecumseh Products Co. Authorized Service Outlet, or by Tecumseh Products Co. at its factory in Grafton, WI. At the time of requesting warranty service, evidence must be presented of the date of sale to the original purchaser. The purchaser shall pay any charges for making service calls and/or for transporting the products to and from the place where the inspection and/or warranty work is performed. The purchaser shall be responsible for any damage or loss incurred in connection with the transportation of any engine or any part(s) thereof submitted for inspection and/or warranty work.

If you have any questions regarding your warranty rights and responsibilities, you should contact Tecumseh Products Co. at
1-414-377-2700.