

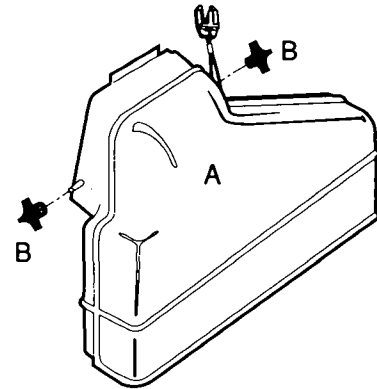

Thank you for purchasing an Attachment for your TROY-BILT Chipper/Vac. We know it will perform to your complete satisfaction if installed and used properly. Refer below to the Attachment you ordered, and check the components shipped to you. Please contact us if you should have any questions at all. (Note: the Vacuum Snout Attachment is available *only* for the 5HP Chipper/Vac model.)

1 CHIPPER/VAC Vacuum Snout Attachment (Part Number 1901113)

Ref. No.	Description	Part No.	Qty.
Vacuum Snout Assembly:			
A	• Vacuum Snout w/ safety interlock lanyard attached	1908402	1
B	• Knob, 1/4"-20	1908590	2



2 CHIPPER/VAC Vacuum Inlet Cap Attachment (Part Number 1901112)

Ref. No.	Description	Part No.	Qty.
Vacuum Inlet Cap Assembly:			
A	• Vacuum Inlet Cap w/ safety interlock lanyard attached	1908615	1
B	• Knob, 1/4"-20	1908590	2

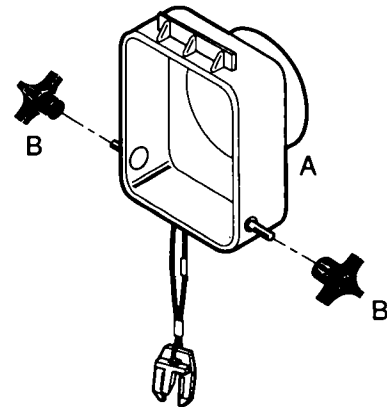

If parts are missing or damaged, contact the Factory or your Authorized Troy-Bilt Dealer for replacement information.

See the Chipper/Vac Owner/Operator Manual for complete instructions on installing and removing the attachment you ordered. The manual also provides detailed instructions for using this attachment. If you do not have an Owner / Operator Manual, please contact the Factory or your local Troy-Bilt Dealer for a free replacement.

! **WARNING**

Be sure to refer to information in your Troy-Bilt Chipper/Vac Owner/Operator Manual for complete operating and safety instructions concerning the installation and use of any attachment.

Failure to follow these instructions could result in serious personal injury.

③ CHIPPER/VAC Rake-In Tray Attachment (Part Number 1901114)

Ref. No.	Description	Part No.	Qty.
Rake-In Tray Assembly:			
A	• Rake-In Tray w/ safety interlock lanyard attached	1908616	1
B	• Knob, 1/4"-20	1908590	2

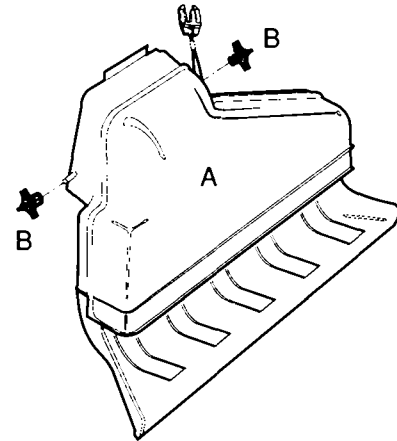

! WARNING

This Troy-Bilt Chipper/Vac is provided with a safety interlock system which prevents the engine from starting unless a vacuuming attachment and the fan cover are installed. It is also designed to shut off the engine if the operator attempts to remove a vacuuming attachment or the fan cover while the engine is running. Never attempt to disconnect or to otherwise defeat the purpose of this system. If the interlock system fails to operate properly, shut off the engine and do not operate the equipment until the system has been repaired and is functioning properly.

Before using the equipment each day, check the operation of the safety interlock system as explained in your Troy-Bilt Chipper/Vac Owner/Operator Manual.

Failure to follow these instructions can result in serious personal injury.

! CAUTION

Before changing vacuuming attachments or screens, or before adjusting fan cover, shut off engine, disconnect spark plug wire from spark plug, and allow all moving parts to come to a complete stop.

Do not operate equipment with vacuum snout unless collection bag is installed.

Failure to follow these instructions can result in serious personal injury.



TROY-BILT MANUFACTURING CO., 102nd St. & 9th Ave., Troy, New York 12180
 For Technical Service call Toll-Free: 1-800-833-6990 — For Parts call Toll-Free: 1-800-648-6776
 GARDEN WAY BRANCH CANADA, 1515 Matheson Blvd. E., Unit B11, Mississauga, Ontario L4W 2P5
 Call Toll Free: 1-800-225-3785

BrentChalmers.com