

OWNER'S GUIDE

TOW BAR KIT (For Chipper Shredders)

Model 290-010-000

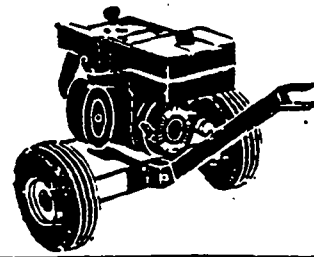

This tow bar kit is an accessory to your chipper shredder. It consists of a tow bar base, a tow bar tongue, and accompanying hardware. Please compare the contents of the carton with the parts list below. If any parts are missing, contact the store from where you purchased, or call 1 (800) 800-7310.

Reference to front or rear of unit is made from the operating position. This position is determined by standing behind the hopper.

PARTS LIST (See Figure 1)

Key No.	Part No.	Description	Qty.
1	681-0134	Tow Bar Base	1
2	681-0133	Tow Bar Tongue	1
3	710-3001	Hex Bolt 3/8-16 x .88	2
4	711-0299	Clevis Pin	1
5	712-0798	Hex Nut 3/8-16	2
6	736-0133	Flat Washer	2
7	711-0835	Clevis Pin	1
8	732-0194	Spring Pin	2
9	736-0169	Lock Washer	2

Figure 1:

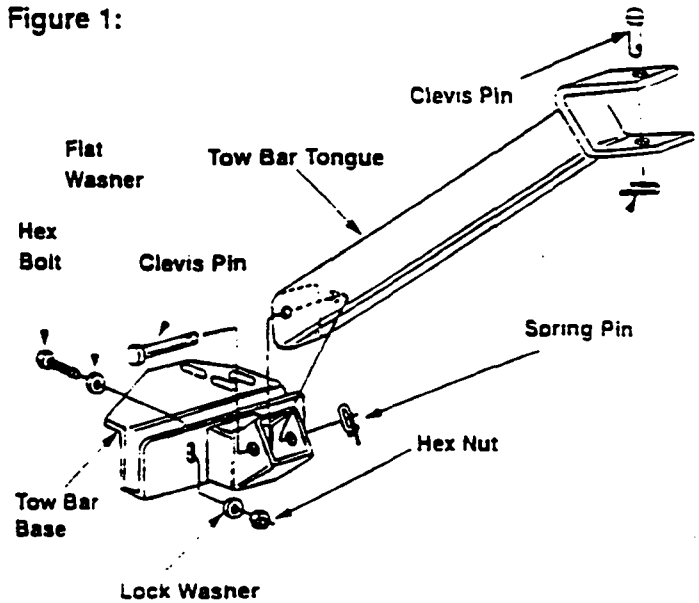
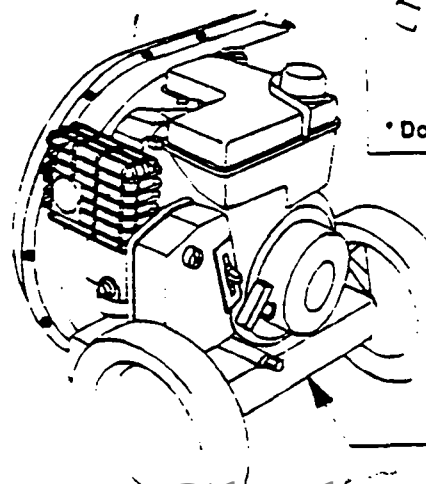
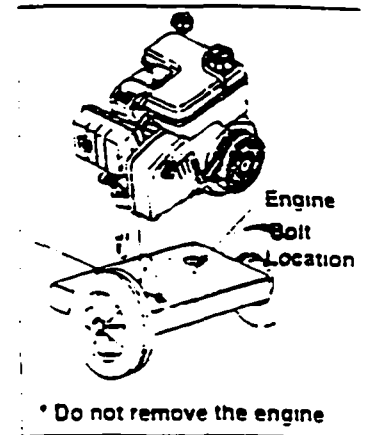

Figure 2:



INSTALLATION

This tow bar installation instruction caters to various models of chipper shredders. Check your chipper shredder unit and follow the instruction that applies.



WARNING: For easier installation, if you decide to tip the chipper shredder backward, make sure to drain the oil and the gasoline from the engine before tipping the unit. Also block the unit securely.

- Remove the hex nut and lock washer from the right front engine bolt. See figure 2 for location of the bolt.

NOTE: For illustration purposes, figure 2 inset shows the bolt location with the engine removed from the frame. However, do not remove the engine from the frame while installing the tow bar.

- Follow the instruction below to place the tow bar base in position. See figure 3.

- a. If the wheel axle on your chipper shredder unit goes through the front upper hole on the side of the frame, place the tow bar in position so the axle is inside the tow bar base.
 - b. If the wheel axle on your chipper shredder goes through the rear lower hole on the side of the frame, place the tow bar base in position so the axle is underneath the tow bar base.
- Select the hole in the tow bar base which aligns with the right front engine mounting bolt, and place base over bolt.
 - Place lock washer over bolt with the cupped side of the washer against the tow bar base (crowned side will go against the hex nut).
 - Thread the hex nut onto the bolt very loosely; do not tighten at this time.
 - Check the front of the shredder frame.
 - a. If two holes are already provided on the frame, proceed to next step.
 - b. If there are no holes on the frame, press the tow bar base against the frame, tighten the nut on the right front engine bolt, and drill two 13/32" holes using the tow bar as a guide.
 - Place flat washers on hex bolts.
 - Insert hex bolt (with washer) into the hole from inside the shredder frame, and through the tow bar base.
 - If the axle is inside the tow bar base, you may need to place the flat washer against the shredder frame, then insert the bolt through the washer, frame and the tow bar base.
 - Secure with lock washer and hex nut on the front of the tow bar base. Do not tighten at this point.
 - Repeat with other hex bolt. Do not tighten.
 - Press the tow bar base firmly against the chipper shredder frame, and tighten both sets of bolts and nuts holding the front of the tow bar base. See Figure 5.
 - Tighten the engine mounting bolt and nut that you had earlier removed.
 - Place the tow bar tongue inside the tow bar base. Align the holes and secure with shorter clevis pin and one spring pin.
 - Use the longer clevis pin and the spring pin to attach the chipper shredder to your lawn tractor. See Figure 5.

REMOVING TOW BAR

- Remove the clevis pin and the spring pin attaching the tow bar tongue to the tractor.
- Remove the longer clevis pin and the spring pin attaching the tow bar tongue to the tow bar base and pull the tongue out of the base. You may keep the tow bar base attached to the chipper shredder.
- If you had drained the engine of oil and gasoline for transporting the unit, refill with fresh oil and gas before operating the unit.

Figure 3:

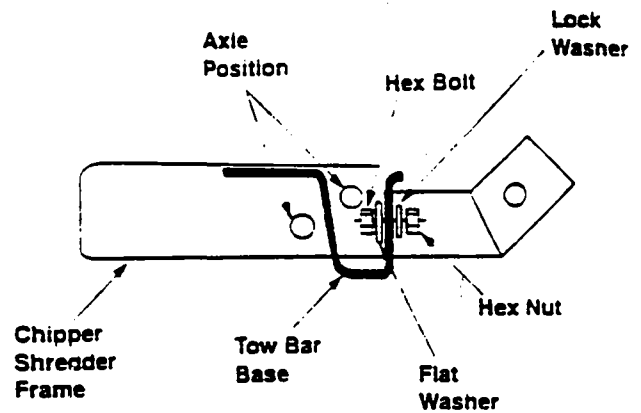

Figure 4:

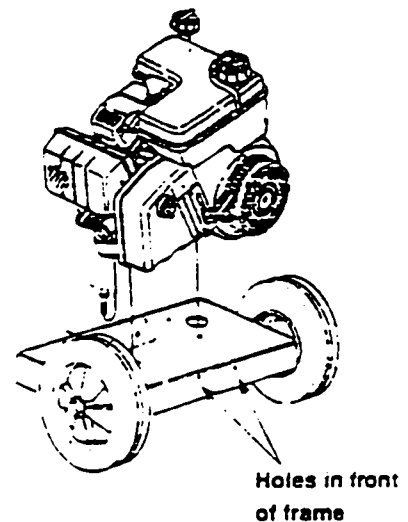

Figure 5:

