

Knife Kit

Kit Number 1772231

⚠ DANGER

Before installing this kit on the unit:

- Stop the engine.
- Wait for all moving parts to stop.
- Disconnect the spark plug wire from the spark plug.

These instructions cover installation of this accessory only and do not attempt to cover major repairs. Read the owner/operator manual provided with the unit before installing this kit.

Kit Description

This kit is designed for the replacement of worn chipper knives.

Preparation

Inspect kit contents as listed below. If parts are missing contact your local dealer or our service department at the addresses on the back of these instructions.

⚠ CAUTION

Use only genuine replacement parts of maintenance or repair. Parts manufactured by others may present safety hazards even though they may fit on the unit.

Fig. 1

Chipper Drum Brake

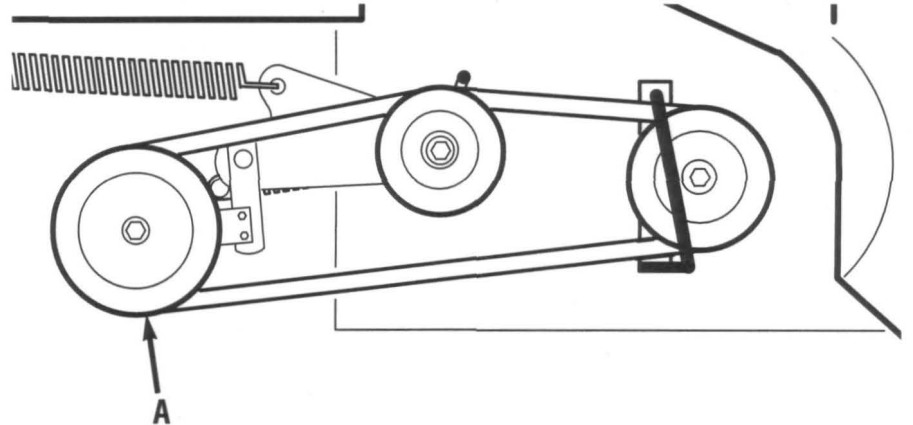

⚠ CAUTION



PINCH POINTS

Do not operate the unit without the belt guard in place.

Chipper Knife Removal

1. Stop the engine and disconnect the spark plug wire.
2. Rotate the chipper drive clutch lever clockwise all the way forward to disengage the chipper drive and relieve tension on the belt.
3. Remove the clutch rod and clutch spring from between the chipper drive clutch lever and the idler pivot.
4. Using a 1/2" wrench, remove the three bolts securing the belt cover to the unit. Remove the belt cover.
5. Remove the belt from around the chipper drum pulley (A, Fig.1).

Kit Contents:

Ref.	Part	Description	Qty.
E	1771511	Socket Head Screw, 1/4-20 x 1-1/2.....	8
F	1908125	Lock Nut, 1/4-20.....	8
G	1770006	Chipper Knife.....	2

⚠ WARNING



EXPOSED KNIVES

The chipper knives are extremely sharp
– use caution when handling them.

- Using a 1/2" wrench, remove the four bolts (B, Fig. 2) securing the cover plate (C) to the top of the unit.
- Lift the cover plate, and turn it over and out of the way. It is not necessary to remove the belt.
- Clean out the hex bolt holes (D, Fig. 3).
- With a 5/32" hex wrench and a 1/2" socket, remove the socket head screws (E) and nuts (F) securing the chipper knives (G) to the chipper drum.
- Carefully remove the chipper knives (G) from the unit.

Chipper Knife Replacement

- Carefully clean the chipper knife seats (K, Fig. 4) on the chipper drum, before securing the knives to the chipper drum. If this surface is not clean, the knives will not lay flat, and damage to the unit and poor chipping performance could occur.

NOTE: Do not re-use the chipper knife hardware. Use the new hardware included in the knife kit.

- Position the new chipper knives (G, Fig. 3) in place into the chipper drum.
- Secure the chipper knives (G) with the new socket head screws (E) and nuts (F), supplied in the kit. Torque the bolts and nuts to 10-12 ft. lbs (14-16 Nm).
- Remove the hopper as instructed in the *Storage* section of the *Chipper Owner Manual*.
- Check the anvil clearance whenever replacing the chipper knives.
 - Adjust the anvil (J, Fig.5) .010" – .040" (.25 – 1mm) away from the chipper knife cutting surfaces. Use a feeler gauge when measuring.
 - Adjust the anvil at nuts (L, Fig.5). Tighten the nuts securely after adjusting.
 - When adjusting the anvil (J), measure at both ends, to ensure the distance is equal all the way along the surfaces of the anvil and the knives.
 - After adjustment, spin the chipper drum to check for interference between the chipper knives (G, Fig. 5) and the anvil (J).
 - The anvil (J) can be reversed and turned over, when the edge becomes dull or rounded.
- Position the cover plate (C, Fig. 2) back into place on the unit (it may be necessary to pull back on the idler pulley to fit the cover plate back in place).

Fig. 2

Cover Plate Removal

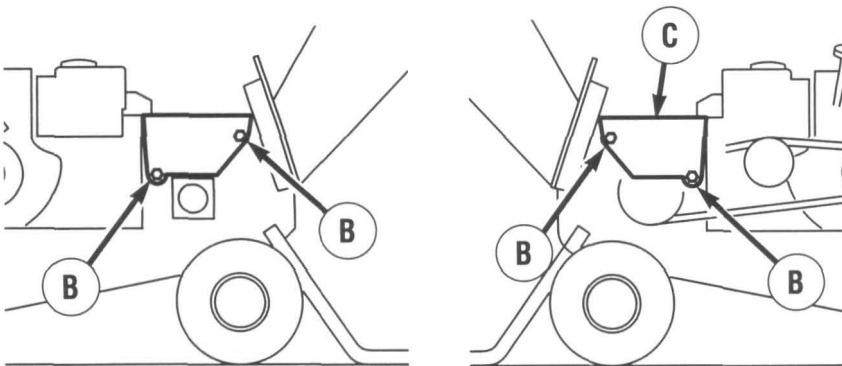

Fig. 3

Chipper Knife Removal

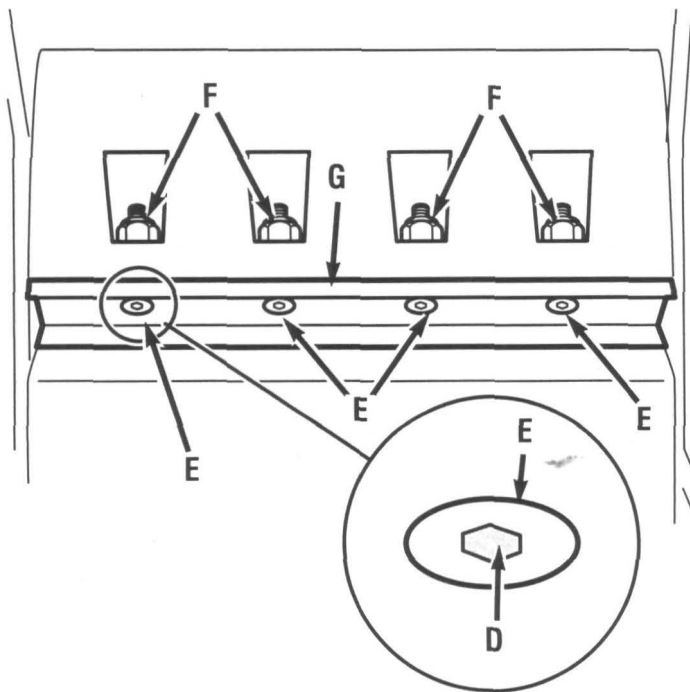

Fig. 4

**Chipper Drum
Cleaning/Chipper
Knife
Replacement**

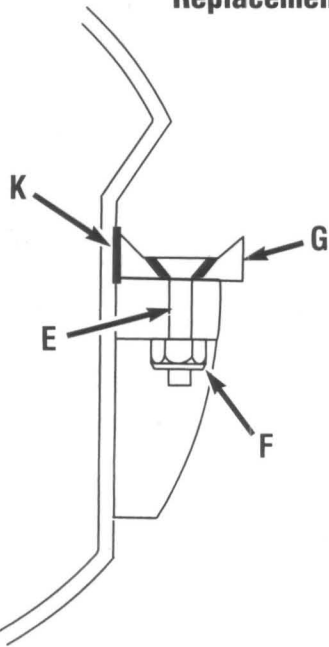

Fig. 5

Chipper Anvil Adjustment

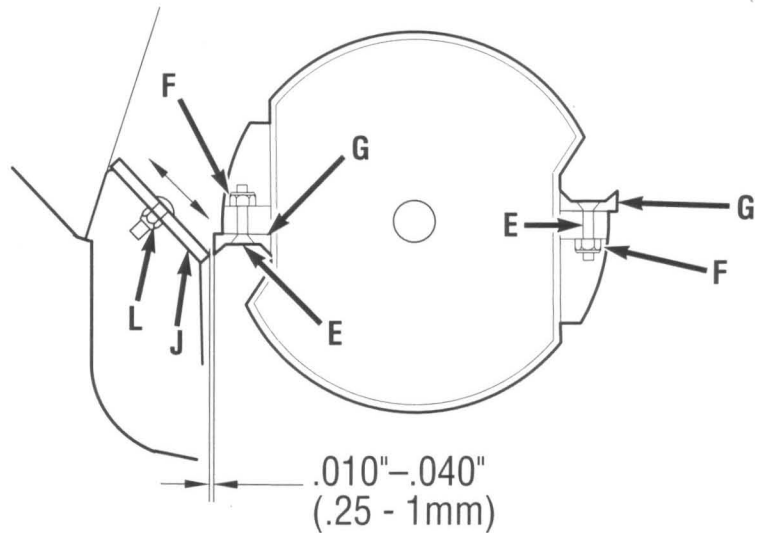
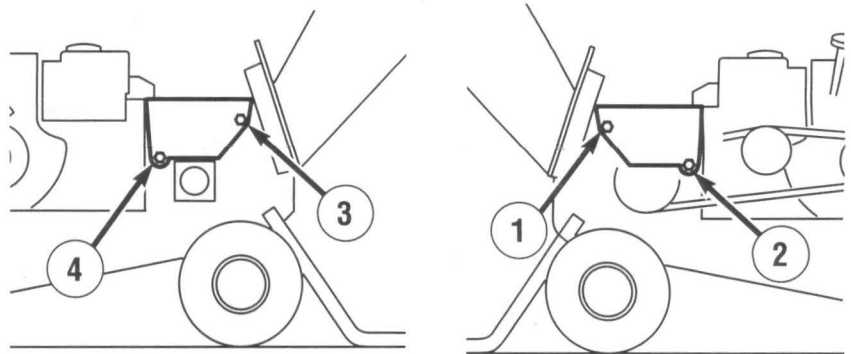

Fig. 6

Cover Plate Tightening Sequence



- Secure the cover plate onto the unit with the four bolts (B, Fig. 2) removed earlier. Tighten the bolts in the sequence shown in Fig. 6.

NOTE: Failure to follow the tightening sequence in Fig. 6 may result in premature belt wear.

- Position the belt back in place around the pulleys, if necessary.
- Replace the clutch rod and clutch spring back onto the unit in between the chipper drive clutch lever and the idler pivot.
- Rotate the chipper drive clutch lever counter-clockwise all the way backward to engage the chipper drive and tension the belt.
- Position the belt cover back onto the unit and secure with the three bolts removed earlier.
- Rotate the chipper drive clutch lever clockwise all the way forward to disengage the chipper drive.
- Reconnect the spark plug wire before attempting to start the unit.

Knife Kit - 1772231

For customer assistance, contact your nearest authorized dealer or:

GARDEN WAY INCORPORATED • 1 Garden Way • Troy, New York U.S.A. 12180

Customer Service: 1-800-437-8686 • Technical Service: 1-800-520-5520 • Parts Service: 1-800-648-6776 • FAX: (518) 391-7332

Outside the U.S.A. and Canada:

Customer Service: (518) 391-7007 • For Technical Service: (518) 391-7008 • Parts Service: (518) 391-7006 or FAX: (518) 391-7332